

ENG

User Guide

2116i/2132i

Temperature/Process indicator
and alarm unit



invensys
EUROTHERM

2132i and 2116i

Temperature and Process Indicator and Alarm Units



Installing and Operating Instructions

Thank you for choosing the 2132i or 2116i indicator and alarm unit. It will provide accurate measurement and display of temperature and other process variables with up to two alarm outputs for operator alert and process protection.

Models 2132i/AL and 2116i/AL are *Indicating alarm units* which come with an alarm relay output and logic I/O fitted.

Models 2132i/ND and 2116i/ND are *Indicator only units* which come without the alarm relay output or logic I/O fitted. Alarms can still be configured and flashed as messages in the main display but they will not be able to operate a physical output.

The indicator is supplied configured according to the ordering code given on page 5. Check the coding on the side labels to determine the configuration of your particular indicator.

DIMENSIONS AND INSTALLATION

Model 2132i

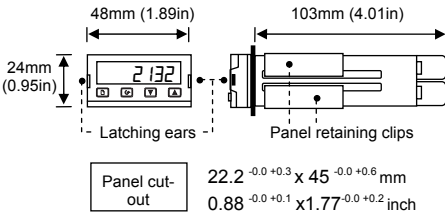

Model 2116i

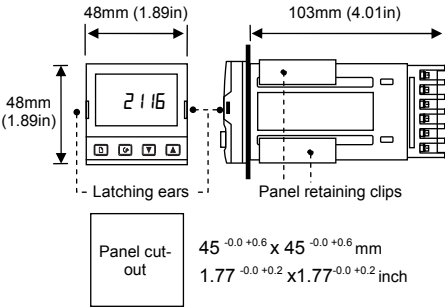

To Install the Indicator

Please read the safety information on pages 5 & 6 before proceeding.

1. Prepare the panel cut-out to the size shown.
2. Insert the indicator through the cut-out.
3. Spring the panel retaining clips into place. Secure the indicator in position by holding it level and pushing both retaining clips forward.
4. Peel off the protective cover from the display

Unplugging the indicator

The indicator can be unplugged from its sleeve by easing the latching ears outwards and pulling it forward out of the sleeve. When plugging the indicator back into its sleeve, ensure that the latching ears click into place to maintain the IP65 sealing.

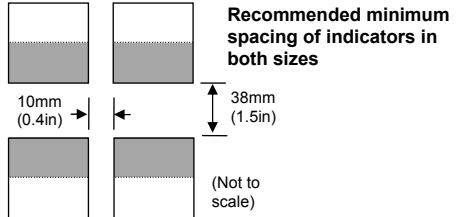

ELECTRICAL CONNECTIONS

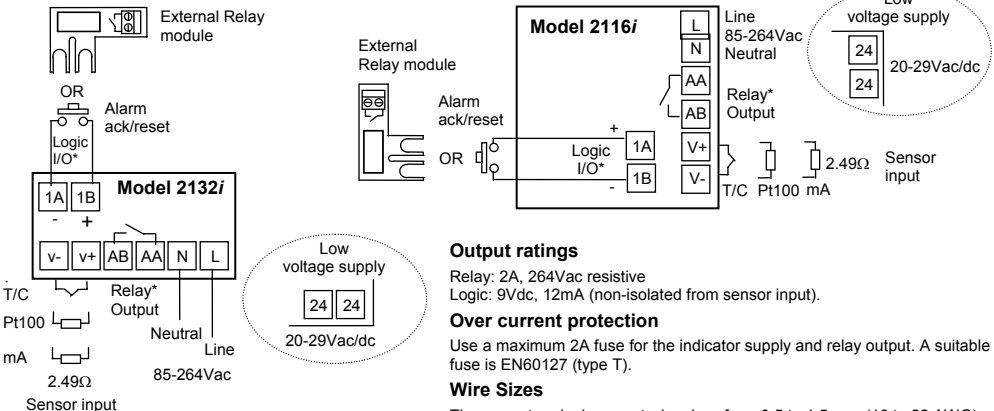

*Not fitted in indicator only units. Also terminals 1A and 1B not fitted in indicator only unit.

Output ratings

Relay: 2A, 264Vac resistive
 Logic: 9Vdc, 12mA (non-isolated from sensor input).

Over current protection

Use a maximum 2A fuse for the indicator supply and relay output. A suitable fuse is EN60127 (type T).

Wire Sizes

The screw terminals accept wire sizes from 0.5 to 1.5 mm (16 to 22 AWG). Hinged covers prevent hands or metal making accidental contact with live wires. The rear terminals screws should be tightened to 0.4Nm (3.5lb in).

OPERATION

Switch on the indicator. Following a 3 second self-test sequence, you will see the display shown below. It is called the HOME display.

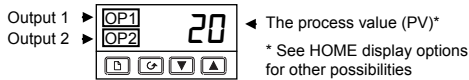

ALARM INDICATION

The indicator has three internal 'soft' alarm setpoints which can be attached to either the logic or relay outputs.

OP1 will flash when an alarm attached to the logic output becomes true. (This is normally alarm 1). It will go steady when the alarm is acknowledged but still true.

OP2 will flash when an alarm attached to the relay output becomes true. (This is normally alarm 2 or 3). It will go steady when the alarm is acknowledged but still true.

TO ACKNOWLEDGE A NEW ALARM

Press **[D]** and **[G]** together. This will also reset any latched alarms that are no longer true.

In addition to the OP beacons, alarm messages are flashed in the main display. The tables below list all of the possible messages and their meaning.

ALARM MESSAGES

Process Alarms	
Message	Meaning
IF5L	Alarm 1 is active and it is a Low alarm.
IF5H	Alarm 1 is active and it is a High alarm.
2F5L	Alarm 2 is active and it is a Low alarm.
2F5H	Alarm 2 is active and it is a High alarm.
3F5L	Alarm 3 is active and it is a Low alarm.
5br	Sensor Break: Input sensor is open circuit or high resistance. Check the sensor.

In addition to the above messages, the displayed process value will flash if the input signal or the displayed value is out of range.

The table above shows normal process alarms. In the event of a failure in the indicator or the sensor the following diagnostic alarm messages are provided.

Diagnostic alarms	
Message	Meaning and (Action)
EEEr	Electrically Erasable Memory Error: A parameter value has been corrupted. Contact Eurotherm Controls.
HwEr	Hardware error. (Return for repair)
LLLL	Low display range exceeded: (Check input signal)
HHHH	High display range exceeded: (Check input signal)
Err1	Error 1: ROM self-test fail. (Return for repair)
Err2	Error 2: RAM self-test fail. (Return for repair)
Err3	Error 3: Watchdog fail. (Return for repair)
Err4	Error 4: Keyboard failure. Stuck button, or a button was pressed during power up.
Err5	Error 5: Input circuit failure. (Return for repair)
PwrF	Power failure. The line voltage is too low.

TO VIEW THE DISPLAY UNITS

Press and release quickly the **[D]** or **[G]** button. The display units will be flashed for 0.5sec

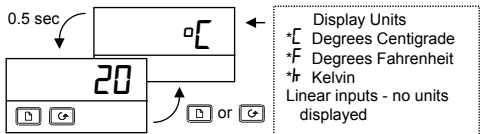

If you get lost, pressing **[D]** and **[G]** together will return you to the HOME display.

If, at any time, no key is pressed within 45 seconds, the display will always return to the HOME display.

HOME DISPLAY OPTIONS

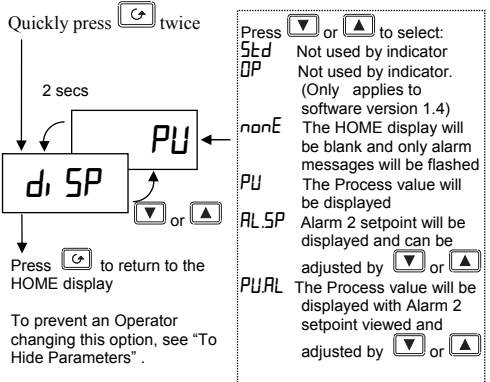

TO CHANGE ALARM SETPOINTS (TRIP LEVELS)

The **[D]** button steps through parameter list headings. The first list is the alarm setpoints. The other lists are shown on the next page.

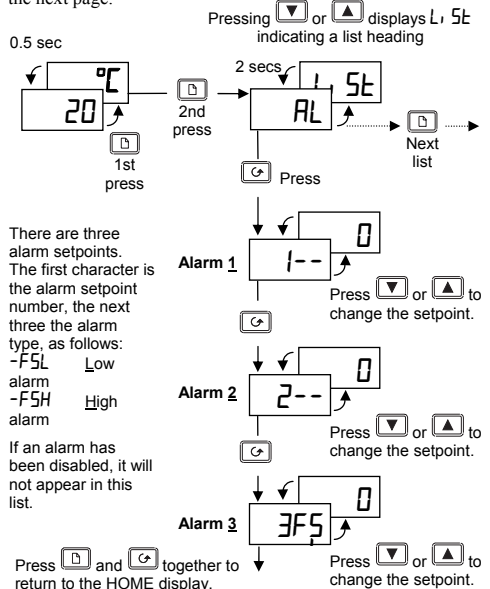

PARAMETER LISTS

Use these lists to change: • Alarm setpoints • Alarm setpoint limits • User calibration

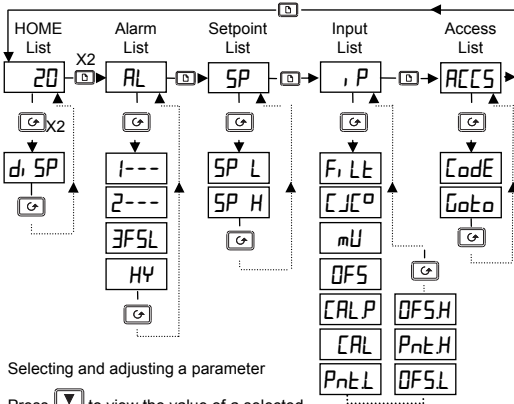

Selecting and adjusting a parameter

Press \downarrow to view the value of a selected parameter. Keep pressing to decrease the value

Press \uparrow to view the value of a selected parameter. Keep pressing to increase the value.

Press \square to step across the list headings.

Press \square to step down the parameters within a particular list. You will eventually return to the list heading.

PARAMETER TABLES

HOME	Home List	Selectable options	Default setting
d, SP	HOME display options	See HOME display options on page 2	PU

AL	Alarm setpoints	Adjustable Range	Default setting
* 1---	Alarm 1 setpoint	Between low and high	0
* 2---	Alarm 2 setpoint	setpoint limits	0
3FSL	Alarm 3 setpoint		0
HY	Alarm hysteresis	1-9999 PV units	1

*In place of dashes, the last three letters indicate the alarm type:
FSL= Low alarm. FSH=High alarm

SP	Setpoint limits	Adjustable Range	Default setting
SP L	Setpoint low limit	Between Process	As per order code
SP H	Setpoint high limit	Value min & max	

I, P	Input List	Adjustable Range	Default setting
F, Lt	Input filter time in secs	OFF-9999	16
DFS	Process value offset	0-9999 units	0
CJC	Cold junction temperature at the rear term's		Read-only
mU	mV input at the rear terminals		Read-only
CAL P	Calibration password	0-9999	3
CAL	Calibration type.	FRAct (Factory) USER (User)	FRAct
Pnt L	Low calibration point	See User Calibration	0
DFSL	Low point offset		0
Pnt H	High calibration point		100
DFSH	High point offset		0

ACCESS	Access list	Used for re-configuring the indicator.
--------	-------------	--

HIDE PARAMETERS OR MAKE THEM READ-ONLY

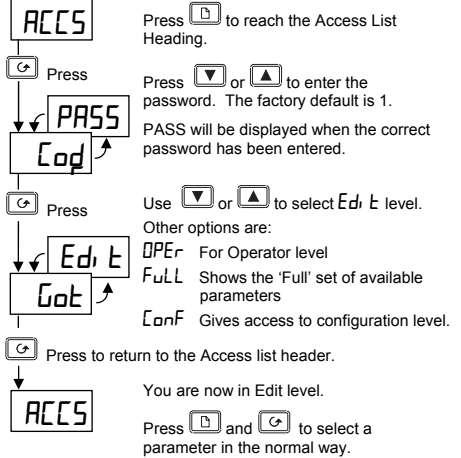

Press \square to reach the Access List Heading.

Press \downarrow or \uparrow to enter the password. The factory default is 1.

PASS will be displayed when the correct password has been entered.

Use \downarrow or \uparrow to select Edit level. Other options are:

OPER For Operator level

FULL Shows the 'Full' set of available parameters

CONF Gives access to configuration level.

Press \square to return to the Access list header.

You are now in Edit level.

Press \square and \square to select a parameter in the normal way.

Example:

High alarm 2 has been selected.

When \downarrow or \uparrow is pressed, instead of displaying the parameter value, its availability to Operator is shown as follows

- ALtr The parameter will be alterable
- Prd The parameter will be 'promoted' into the HOME list
- rERd The parameter will be read-only
- Hi dE The parameter will be hidden.

Repeat for all the parameters you wish to hide or make read-only then return to operator level:

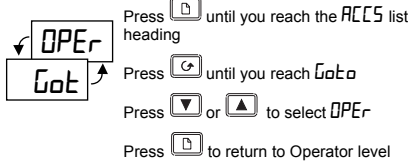

Press \square until you reach the ACCESS list heading

Press \square until you reach Goto

Press \downarrow or \uparrow to select OPER

Press \square to return to Operator level

USER CALIBRATION

Your indicator has been calibrated for life against known reference sources in the factory. User calibration allows you to apply offsets to compensate for sensor and other system errors. The parameter DFS in the I, P list applies a fixed offset over the whole display range. You may also apply a 2-point calibration as follows:

- Press \square until you reach the I, P list
- Press \square until you reach the CAL P parameter
- Press \downarrow or \uparrow to enter the password. The factory default is 3. PASS will be displayed when correct.
- Press \square to reach the CAL parameter
- Press \downarrow or \uparrow to select USER (FRAct will restore the factory calibration)
- Apply 2-point calibration as below:

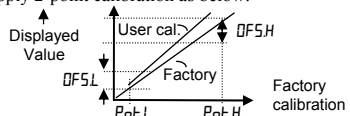

CONFIGURING THE INDICATOR

Select configuration level to change: • Display units • Input sensor type • Scaling of linear inputs • Alarm configuration • Passwords.

To select configuration level

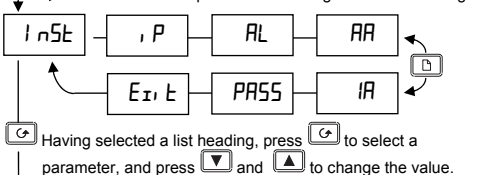
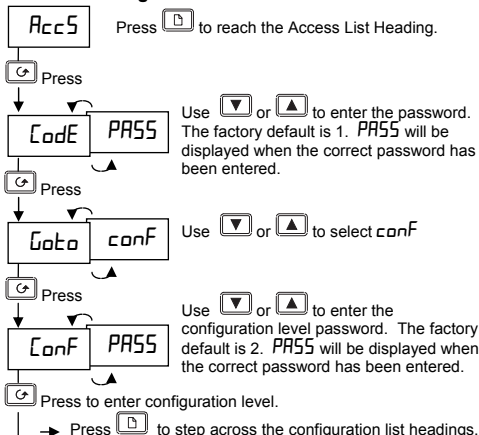

InSt	Instrument list	Options	Meaning
uni t	Display units	°C °F °K none	Centigrade Fahrenheit Kelvin None (for linear inputs)
dEC P	Decimal places in display	none one two	None One Two
Ctrl	Control type	AL	Always set to AL

Selecting **OnDF** or **Pd** will convert the indicator into a controller which requires separate instructions.

The parameters that follow, (**Act**, **Pdtr** and **Pwrf**), are not used by the indicator and require separate instructions.

IP	Sensor Input	Options	Meaning
InPt	Input type	Jtc	J thermocouple
		Ktc	K thermocouple
		Ltc	L thermocouple
		Rtc	R thermocouple
		Btc	B thermocouple
		Ntc	N thermocouple
		Ttc	T thermocouple
		Stc	S thermocouple
		PL 2	Platinell II
		rEd	100Ω Pt thermometer
Ctc	Custom input- C=st'd	Linear mV	
CJC	Cold junction compensation	OFF	OFF - Linear inputs only
		Auto	Automatic
ImP	Sensor break input impedance	Auto	1.5KΩ, Hi =5KΩ, Hi Hi = 15KΩ

Linear input scaling (-12.00 to +80.00mV)	
InPL	mV input low
InPH	mV input high
UAL L	Displayed value low
UAL H	Displayed value high

Alarm Configuration

The **AL** list configures the three internal 'soft' alarms and causes the appropriate alarm message to be flashed in the HOME display.

AL	Alarm list	Options	Meaning
AL 1	Alarm 1	OFF FSL FSH	The alarm is disabled Low alarm High alarm
	<i>Not used in the indicator</i>	dBu dH dLo	Deviation band alarm Deviation high alarm Deviation low alarm
Ltch	Alarm latching	no YES mAn	Non-latching Special - Not used Latched (manual reset)
bLoc	Alarm blocking	no YES	No blocking Blocked until first good

The above sequence is repeated for **AL 2** & **AL 3** (Alarms 2 & 3)

SPLi	Alarm setpoint limits	d: 5	Con	Meaning
				Limited by display range Limited by setpoint limits

Relay and Logic input/output Configuration

The internal soft alarms may be attached to the relay and logic outputs. The logic can be configured as an output or input.

AA	Relay output	Options	Meaning
IA	Logic output		
id	Identity of output	rELY LoG	Relay Logic
Func	Function	d: G	Digital output
	Logic only	Ac AL	Alarm Ack input
Functions: HEAL , COOL , SSr , I and rrES are not used by the indicator and require separate instructions			
d: GF	Digital output functions	nach CLF	No change Clear all alarms
	Any combination of alarms can be attached to the logic or relay output. Press ▲ and ▼ to select a desired alarm. After a two second pause the display blinks and returns to d: GF . Pressing ▲ and ▼ again will show two decimal points in those alarms that have been added to the output.	IFSL ZFSL 3FSL Sbf	Alarm 1* Alarm 2* Alarm 3* Sensor break
	Functions: Lbr , LdF , mAn , End , & EmG I , to EmG 4 are not used by the indicator and need separate instructions	nW	New alarm
	Sense of the output.	nor Inu	Normal Inverted
	Inu = output de-energised in alarm		

*The last three letters will correspond to the alarm type set in the **AL** list. If the alarm is disabled, **AL 1** or **AL 2** or **AL 3** will be shown.

Passwords

PASS	Passwords	Range	Default
ACC P	Full and Edit level password	0-9999	1
ConP	Configuration level password	0-9999	2
CAL P	User calibration password	0-9999	3

To leave Configuration level

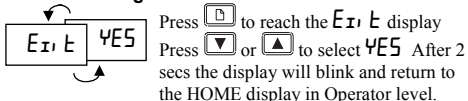

ORDERING CODE

The indicator is supplied configured to the ordering code shown below.

1	2	3	4	5	6	7	8	9	10	11	12
---	---	---	---	---	---	---	---	---	----	----	----

1. Model Number
2132i 1/8 DIN indicator
2116i ¼ DIN indicator

2. Function
ND Indicator only*
AL Indicating alarm unit

3. Supply voltage
VH 85-264Vac
VL 20 -29V dc or ac

4. Manual
XXX None
ENG English
FRA French
GER German
NED Dutch
SPA Spanish
SWE Swedish
ITA Italian

5. Logic I/O
XX Disabled*
Logic input
AC Alarm ack/reset
KL Keylock
Non-latched alarms
FH High alarm 1
FL Low alarm 1
Latched alarms
HA High alarm 1
LA Low alarm 1
NW New alarm

7. Sensor input	8 & 9. Display range and Setpoint min & max limits	
	°C	°F
Thermocouples		
J Type J	-210 to 1200	-340 to 2192
K Type K	-200 to 1372	-325 to 2500
T Type T	-200 to 400	-325 to 750
L Type L	-200 to 900	-325 to 1650
N Type N	-200 to 1300	-325 to 2370
R Type R	-50 to 1768	-58 to 3200
S Type S	-50 to 1768	-58 to 3200
B Type B	0 to 1820	32 to 3308
P Platinell II	0 to 1369	32 to 2496
Resistance thermometer		
Z Pt100	-200 to 850	-325 to 1562
Custom downloaded inputs		
C Type C -W5%Re/W26%Re (default custom sensor)	0 to 2319	32 to 4200
D Type D - W3%Re/W25%Re	0 to 2399	32 to 4350
E E thermocouple	-200 to 999	-325 to 1830
1 Ni/Ni18%Mo	0 to 1399	32 to 2550
2 Pt20%Rh/Pt40%Rh	0 to 1870	32 to 3398
3 W/W26%Re (Engelhard)	0 to 2000	32 to 3632
4 W/W26%Re (Hoskins)	0 to 2010	32 to 3650
5 W5%Re/W26%Re (Engelhard)	10 to 2300	50 to 4172
6 W5%Re/W26%Re(Bucose)	0 to 2000	32 to 3632
7 Pt10%Rh/PM40%Rh	200 to 1800	392 to 3272
8 Exergen K80 I.R. Pyrometer	-45 to 650	-49 to 1202
Process inputs (linear)		
M -9.99 to +80mV	Scalable	-999 to 9999
Y 0 to 20mA	Scalable	-999 to 9999
A 4 to 20mA	Scalable	-999 to 9999
V 0 to 10Vdc (input adapter required)	Scalable	-999 to 9999

6. Alarm Relay Output
XX Disabled*
Non-latched alarms
FH High alarm 2
FL Low alarm 2
AL High alarm 2 & low alarm 3
Latched alarms
HA High alarm 2
LA Low alarm 2
AA High alarm 2 & low alarm 3
NW New alarm

10. Units
°C C K Kelvin
°F F X Linear input

11. External relay module
XX Not fitted
R7 Fitted (Operated by the logic output)

12. Input Adaptor
XX None
V1 0-10Vdc
A1 0-20mA sense resistor (2.49Ω, 0.1%)

*If 'ND' (Indicator only) is specified in the function field, then XX must be entered in the Logic I/O and alarm 2 relay fields.

TECHNICAL SPECIFICATION

Display	4 digit, green. 10mm high characters
Supply voltage	High voltage unit: 100Vac -15% to 240Vac +10%, 48-62Hz. Power consumption: 5Watts maximum Low voltage unit: 24Vdc or ac -15%, +20% DC to 62Hz, Power consumption: 5Watts maximum
Operating ambients	0 to 55°C. 5 to 95%RH, non condensing
Storage temperature	-20°C to +75°C.
Output ratings	Relay(isolated): Maximum: 264Vac, 2A resistive. Minimum: 12Vdc, 100mA Logic I/O: 9Vdc at 18mA (non-isolated from sensor input). Can be used as alarm output or alarm acknowledge input
Calibration accuracy	± 1°C or ±0.25% of reading whichever is greater
Cold junction compensation	>30 to 1 rejection of ambient temperature change. Uses INSTANT ACCURACY™ cold junction sensing technology to eliminate warm-up drift and respond rapidly to ambient temperature changes.
Input filtering	Off to 999.9 seconds
EMC standards	Emissions and immunity standard EN61326 suitable for industrial environments.
Safety standard	EN 61010. Installation category II. (Voltage transients on the power supply must not exceed 2.5kV). Pollution degree 2. All isolated inputs and outputs have reinforced insulation to protect against electric shock.
Atmosphere	Not suitable for use above 2000m or in explosive or corrosive atmospheres
Panel sealing	IP65 (EN 60529), or NEMA 4X

SAFETY AND EMC INFORMATION

This indicator is intended for industrial temperature and process applications when it will meet the requirements of the European Directives on Safety and EMC. Use in other applications, or failure to observe the installation instructions of this handbook may impair safety or EMC. The installer must ensure the safety and EMC of any particular installation.

Safety

This indicator complies with the European Low Voltage Directive 73/23/EEC, by the application of the safety standard EN 61010.

Electromagnetic compatibility

This indicator conforms with the essential protection requirements of the EMC Directive 89/336/EEC, by the application of a Technical Construction File. This instrument satisfies the general requirements of the industrial environment defined in EN 61326. For more information on product compliance refer to the Technical Construction File.

GENERAL

The information contained in this manual is subject to change without notice. While every effort has been made to ensure the accuracy of the information, your supplier shall not be held liable for errors contained herein.

Unpacking and storage

The packaging should contain an instrument mounted in its sleeve, two mounting brackets for panel installation and an Installation & Operating guide. Certain ranges are supplied with an input adapter.

If on receipt, the packaging or the instrument is damaged, do not install the product but contact your supplier. If the instrument is to be stored before use, protect from humidity and dust in an ambient temperature range of -20°C to +75°C.

Service and repair

This indicator has no user serviceable parts. Contact your supplier for repair.

Caution: Charged capacitors

Before removing an instrument from its sleeve, disconnect the supply and wait at least two minutes to allow capacitors to discharge. It may be convenient to partially withdraw the instrument from the sleeve, then pause before completing the removal. In any case, avoid touching the exposed electronics of an instrument when withdrawing it from the sleeve.

Failure to observe these precautions may cause damage to components of the instrument or some discomfort to the user.

Electrostatic discharge precautions

When the indicator is removed from its sleeve, some of the exposed electronic components are vulnerable to damage by electrostatic discharge from someone handling the indicator. To avoid this, before handling the unplugged indicator discharge yourself to ground.

Cleaning

Do not use water or water based products to clean labels or they will become illegible. Isopropyl alcohol may be used to clean labels. A mild soap solution may be used to clean other exterior surfaces of the product.

INSTALLATION SAFETY REQUIREMENTS

Safety Symbols

Various symbols may be used on the indicator. They have the following meaning:



Caution, (refer to accompanying documents)



Equipment protected throughout by DOUBLE INSULATION

Personnel

Installation must only be carried out by suitably qualified personnel in accordance with the instructions in this handbook.

Enclosure of Live Parts

To prevent hands or metal tools touching parts that may be electrically live, the indicator must be enclosed in an enclosure.

Caution: Live sensors

The indicator is designed to operate if the temperature sensor is connected directly to an electrical heating element. However, you must ensure that service personnel do not touch connections to these inputs while they are live. With a live sensor, all cables, connectors and switches for connecting the sensor must be mains rated for use in 240Vac CATII.

Wiring

It is important to connect the indicator in accordance with the wiring data given in this guide. Take particular care not to connect AC supplies to the low voltage sensor input or other low level inputs and outputs. Only use copper conductors for connections (except thermocouple inputs) and ensure that the wiring of installations comply with all local wiring regulations. For example in the UK use the latest version of the IEE wiring regulations, (BS7671). In the USA use NEC Class I wiring methods.

Power Isolation

The installation must include a power isolating switch or circuit breaker. This device should be in close proximity to the indicator, within easy reach of the operator and marked as the disconnecting device for the instrument.

Overcurrent protection

The power supply to the system should be fused appropriately to protect the cabling to the units.

Voltage rating

The maximum continuous voltage applied between any of the following terminals must not exceed 240Vac:

- relay output to logic, dc or sensor connections;
- any connection to ground.

The indicator must not be wired to a three phase supply with an unearthed star connection. Under fault conditions such a supply could rise above 240Vac with respect to ground and the product would not be safe.

Conductive pollution

Electrically conductive pollution must be excluded from the cabinet in which the indicator is mounted. For example, carbon dust is a form of electrically conductive pollution. To secure a suitable atmosphere in conditions of conductive pollution, fit an air filter to the air intake of the cabinet. Where condensation is likely, for example at low temperatures, include a thermostatically controlled heater in the cabinet.

This product has been designed to conform to BSEN61010 installation category II, pollution degree 2. These are defined as follows:-

Installation Category II (CAT II)

For equipment on nominal 230V supply, the maximum rated impulse voltage is 2500V.

Pollution Degree 2

Normally only non conductive pollution occurs. Occasionally, however, a temporary conductivity caused by condensation shall be expected.

Grounding of the temperature sensor shield

In some installations it is common practice to replace the temperature sensor while the indicator is still powered up. Under these conditions, as additional protection against electric shock, we recommend that the shield of the temperature sensor is grounded. Do not rely on grounding through the framework of the machine.

Over-temperature protection

When designing any control system it is essential to consider what will happen if any part of the system should fail. In temperature control applications the primary danger is that the heating will remain constantly on. Apart from spoiling the product, this could damage any process machinery being controlled, or even cause a fire.

Reasons why the heating might remain constantly on include:

- the temperature sensor becoming detached from the process
- thermocouple wiring becoming short circuit;
- the controller failing with its heating output constantly on
- an external valve or contactor sticking in the heating condition
- the controller setpoint set too high.

Where damage or injury is possible, we recommend fitting a separate over-temperature protection unit, with an independent temperature sensor, which will isolate the heating circuit.

This indicator can be used in addition to a controller as an over temperature device. It is recommended that the relay used to indicate the alarm condition should be set to high alarm configured with sensor break and inverse 'N/O' operation so that it relaxes to the alarm condition when power is removed.

Installation requirements for EMC

To ensure compliance with the European EMC directive certain installation precautions are necessary as follows:

- For general guidance refer to Eurotherm Controls EMC Installation Guide, HA025464.
- When using relay outputs it may be necessary to fit a filter suitable for suppressing the emissions. The filter requirements will depend on the type of load. For typical applications we recommend Schaffner FN321 or FN612.
- If the unit is used in table top equipment which is plugged into a standard power socket, then it is likely that compliance to the commercial and light industrial emissions standard is required. In this case to meet the conducted emissions requirement, a suitable mains filter should be installed. We recommend Schaffner types FN321 and FN612.

Routing of wires

To minimise the pick-up of electrical noise, the low voltage DC connections and the sensor input wiring should be routed away from high-current power cables. Where it is impractical to do this, use shielded cables with the shield grounded at both ends. In general keep cable lengths to a minimum.

Restriction of Hazardous Substances (RoHS)

Product group 2100

Table listing restricted substances

Chinese

限制使用材料一览表

产品 2100	有毒有害物质或元素					
	铅	汞	镉	六价铬	多溴联苯	多溴二苯醚
印刷电路板组件	X	O	X	O	O	O
附属物	O	O	O	O	O	O
显示器	X	O	O	O	O	O
模块	X	O	X	O	O	O
O	表示该有毒有害物质在该部件所有均质材料中的含量均在SJ/T11363-2006标准规定的限量要求以下。					
X	表示该有毒有害物质至少在该部件的某一均质材料中的含量超出SJ/T11363-2006标准规定的限量要求。					

English

Restricted Materials Table

Product 2100	Toxic and hazardous substances and elements					
	Pb	Hg	Cd	Cr(VI)	PBB	PBDE
PCBA	X	O	X	O	O	O
Enclosure	O	O	O	O	O	O
Display	X	O	O	O	O	O
Modules	X	O	X	O	O	O
O	Indicates that this toxic or hazardous substance contained in all of the homogeneous materials for this part is below the limit requirement in SJ/T11363-2006.					
X	Indicates that this toxic or hazardous substance contained in at least one of the homogeneous materials used for this part is above the limit requirement in SJ/T11363-2006.					

Approval

Name:	Position:	Signature:	Date:
-------	-----------	------------	-------

Martin Greenhalgh

Quality Manager

Martin Greenhalgh

09/15/2007



This indicator meets the European directives on safety and EMC

INTERNATIONAL SALES AND SERVICE

AUSTRALIA Sydney

Eurotherm Pty. Ltd.
Telephone (+61 2) 9838 0099
Fax (+61 2) 9838 9288
E-mail info.au@eurotherm.com

AUSTRIA Vienna

Eurotherm GmbH
Telephone (+43 1) 798 7601
Fax (+43 1) 798 7605
E-mail info.at@eurotherm.com

BELGIUM & LUXEMBOURG Moha

Eurotherm S.A./N.V.
Telephone (+32) 85 274080
Fax (+32) 85 274081
E-mail info.be@eurotherm.com

BRAZIL Campinas-SP

Eurotherm Ltda.
Telephone (+5519) 3707 5333
Fax (+5519) 3707 5345
E-mail info.br@eurotherm.com

DENMARK Copenhagen

Eurotherm Danmark AS
Telephone (+45 70) 234670
Fax (+45 70) 234660
E-mail info.dk@eurotherm.com

FINLAND Abo

Eurotherm Finland
Telephone (+358) 2250 6030
Fax (+358) 2250 3201
E-mail info.fi@eurotherm.com

FRANCE Lyon

Eurotherm Automation SA
Telephone (+33 478) 66 45 00
Fax (+33 478) 35 24 90
E-mail info.fr@eurotherm.com

GERMANY Limburg

Eurotherm Deutschland GmbH
Telephone (+49 6431) 2980
Fax (+49 6431) 298119
E-mail info.de@eurotherm.com

HONG KONG & CHINA

Eurotherm Limited North Point
Telephone (+85 2) 28733826
Fax (+85 2) 28700148
E-mail info.hk@eurotherm.com

Guangzhou Office

Telephone (+86 20) 8755 5099
Fax (+86 20) 8755 5831
E-mail info.cn@eurotherm.com

Beijing Office

Telephone (+86 10) 6567 8506
Fax (+86 10) 6567 8509
E-mail info.cn@eurotherm.com

Shanghai Office

Telephone (+86 21) 6145 1188
Fax (+86 21) 6145 1187
E-mail info.cn@eurotherm.com

INDIA Chennai

Eurotherm India Limited
Telephone (+91 44) 2496 1129
Fax (+91 44) 2496 1831
E-mail info.in@eurotherm.com

IRELAND Dublin

Eurotherm Ireland Limited
Telephone (+353 1) 4691800
Fax (+353 1) 4691300
E-mail info.ie@eurotherm.com

ITALY Como

Eurotherm S.r.l.
Telephone (+39 031) 975111
Fax (+39 031) 977512
E-mail info.it@eurotherm.com

KOREA Seoul

Eurotherm Korea Limited
Telephone (+82 31) 273 8507
Fax (+82 31) 273 8508
E-mail info.kr@eurotherm.com

NETHERLANDS Alphen a/d Rijn

Eurotherm B.V.
Telephone (+31 172) 411752
Fax (+31 172) 417260
E-mail info.nl@eurotherm.com

NORWAY Oslo

Eurotherm A/S
Telephone (+47 67) 592170
Fax (+47 67) 118301
E-mail info.no@eurotherm.com

POLAND Katowice

Eurotherm Sp Z o.o.
Telephone (+48 32) 2185100
Fax (+48 32) 2177171
E-mail info.pl@eurotherm.com

SPAIN Madrid

Eurotherm España SA
Telephone (+34 91) 6616001
Fax (+34 91) 6619093
E-mail info.es@eurotherm.com

SWEDEN Malmö

Eurotherm AB
Telephone (+46 40) 384500
Fax (+46 40) 384545
E-mail info.se@eurotherm.com

SWITZERLAND Wollerau

Eurotherm Produkte (Schweiz) AG
Telephone (+41 44) 787 1040
Fax (+41 44) 787 1044
E-mail info.ch@eurotherm.com

UNITED KINGDOM Worthing

Eurotherm Limited
Telephone (+44 1903) 268500
Fax (+44 1903) 265982
E-mail info.uk@eurotherm.com
Web www.eurotherm.co.uk

U.S.A Leesburg VA

Eurotherm Inc.
Telephone (+1 703) 443 0000
Fax (+1 703) 669 1300
E-mail info.us@eurotherm.com
Web www.eurotherm.com

ED54

Invensys, Eurotherm, the Eurotherm logo, Chessell, EurothermSuite, Mini8, Eycan, Eyriss and Wonderwear are trademarks on Invensys plc, its subsidiaries and affiliates. All other brands may be trademarks of their respective owners.

© Copyright Eurotherm Limited 2007

All rights are strictly reserved. No part of this document may be reproduced, modified, or transmitted in any form by any means, nor may it be stored in a retrieval system other than for the purpose to act as an aid in operating the equipment to which the document relates, without the prior written permission of Eurotherm limited.

Eurotherm Limited pursues a policy of continuous development and product improvement. The specifications in this document may therefore be changed without notice. The information in this document is given in good faith, but is intended for guidance only. Eurotherm Limited will accept no responsibility for any losses arising from errors in this document.

