Thyristor Power units and Driver units

470 series

Single-phase resistive and inductive load true power control

User Manual

© Copyright Eurotherm Automation 1996

All rights reserved. All reproduction or transmission in any form or using any procedure (electronic or mechanical, including photocopying and recording) without the written permission of EURO THERM AUTOMATION is strictly prohibited. EURO THERM AUTOMATION have taken particular care to ensure the accuracy of these specifications. However, in order to maintain our technological lead, we are dedicated to the continual improvement of our products and this may lead to modifications or omissions in the current specifications. We cannot be held responsible for any material or bodily damage, losses or costs incurred.

The installation, configuration, commissioning and maintenance of the power unit must only be performed by a person **qualified and authorised to perform work in an industrial low voltage electrical environment**.

Important precautions and special information are indicated in the manual by two symbols:



WARNING

This symbol means that failure to take note of the information may have serious consequences for the safety of personnel and may even result in the risk of electrocution.



CAUTION

This symbol means that failure to take note of the information may

- **have serious consequences for the installation**
- **result in the incorrect functioning of the power unit.**

These marks must indicate specific points.
The entire manual remains applicable.

It is the responsibility of the user and it is highly recommended, given the value of the equipment controlled using 470, to install **independent safety** devices.

This alarm must be tested regularly.

Eurotherm can supply suitable equipment.

As a result of the constant improvement of its products, Eurotherm may modify these specifications without warning.
For any further information and if in doubt, please contact your EUROTHERM office where technicians are at your disposal should you require advice or assistance with the commissioning of your installation.

EUROPEAN DIRECTIVES

ELECTROMAGNETIC COMPATIBILITY (EMC)

For industrial environments, excluding residential environments

The **470** products are considered as components without any direct function as defined in the EMC Directive. The system or installation in which these products are incorporated must comply with the essential protection requirements of the EMC Directive.

However, Eurotherm certifies that the **470** products, when installed and used in accordance with their User Manual, meets the following test standards and enables the system or installation in which there are installed to comply with the EMC Directive in regards to the **470** products.

Tests		Test standards	Edition
Immunity	Electrostatic discharge	IEC 1000-4-2 (EN 61000-4-2)	06/1995
	Fast transients	IEC 1000-4-4 (EN 61000-4-4)	01/1995
	Radioelectric frequency electromagnetic fields	IEC 801-3 (prEN 61000-4-3)	1984
Emission	Radiated	EN 55011	1991
	Conducted (the choice of the applicable standard depends on the application)	EN 50081-2 With an external filter	1991
		IEC 1800-3 (prEN 61800-3) Without external filter. Applies for the second environment	1996

In order to guarantee the best service, Eurotherm has validated the compliance of the **470** products with these test standards through design and laboratory tests that have been validated with a Technical Construction File by a Competent Body, **LCIE** (Laboratoire Central des Industries Électriques).

EXTERNAL SERIES FILTERS

To reduce the conducted emissions that occur when using thyristor units, Eurotherm can supply external filters.

Nominal current of 470	Serial filter order code
25 A to 60 A 75 A and 100 A 150 A	FILTER/TRI/63A/00 FILTER/TRI/100A/00 FILTER/TRI/160A/00



SAFETY

The **470** products installed and used in accordance with this User Manual are designed to comply with the essential protection requirements of the Low Voltage Directive 73/23EEC dated 19/02/73 (amended by Directive 93/68/EEC dated 22/07/93).

CE MARK

The CE Mark of **470** products implies that the essential protection requirements of the Low Voltage Directive are observed.

The **470** Technical Construction File is approved by a Notified Body, **LCIE** (Laboratoire Central des Industries Électriques).

CE DECLARATION OF CONFORMITY

A CE Declaration of Conformity is available on request.

FURTHER INFORMATION

For further information on CE Mark, please contact your nearest Eurotherm office.

This **470 User Manual (Part No. HA 174836)** intends for the 470 series power thyristor units manufactured from **May 1996**.

The 470 User Manual (Part No. HA 020134) is valid for products manufactured before this date.

In order to help you reduce risks related to the effects of electromagnetic interference depending on the installation of the product, Eurotherm can supply you with the "**EMC Installation Guide**" (Part No. HA 025464).

This guide gives the rules generally applicable for Electromagnetic compatibility.

Manufactured by Eurotherm Automation S.A.
ISO 9001 - EN 29001 certified

470 USER MANUAL

The safety instructions for the installation and use of 470 series units are given in the pages below:

- installation 2-2, 2-4
- wiring 3-2, 3-11, 3-13, 3-14, 3-24
- configuration 4-2
- commissioning 6-2, 6-10
- fuse protection 7-2,7-4
- maintenance 7-5

Contents

Chapter 1 IDENTIFYING THE THYRISTOR UNITS Page

General introduction to the 470 series	1-2
Technical data	1-6
Power	1-6
Environment	1-6
Control	1-7
Retransmissions	1-8
Current limit	1-8
Power limit	1-8
Partial load failure detection	1-8
Thyristor unit coding	1-9
Backplate	1-10
Short or full code	1-10
Coding example	1-11
470 series thyristor unit and installation parameters	1-11
Thyristor unit coding	1-11
Serial number labels	1-12

Chapter 2 INSTALLATION

Safety during installation	2-2
Dimensions	2-3
Mechanical mounting	2-4

Contents (Continued)

Page

Chapter 3 WIRING

Safety during wiring	3-2
Fixing the power cables	3-3
User terminal blocks	3-5
Auxiliary power supply	3-6
Alarm relay contact	3-7
Load voltage information	3-8
Control cables	3-9
Fixing	3-9
Connecting the shield to the ground	3-10
Control terminal block	3-11
Driver terminal block	3-13
Input signals	3-14
Safety quench	3-14
Inhibit	3-14
External control connection	3-15
Control of multiple thyristor units	3-16
Parallel input connection	3-16
Serial input connection	3-16
Manual control connection	3-17
Current limit connection (optional)	3-18
Limit set using the potentiometer on the front panel	3-18
Limit set using an external voltage	3-19
Limit set using an external potentiometer	3-20
Power limit connection	3-21
Limit set using the potentiometer on the front panel	3-21
Limit set using an external potentiometer	3-22
Limit set using an external voltage	3-22
Retransmission signals	3-23
External thyristor block control (472 model)	3-24
Examples of wiring diagrams	3-26
470 and 471 model thyristor units	3-26
Driver unit, 472 model	3-28

Contents (Continued)

Chapter 4 CONFIGURATION

Page

Safety during configuration	4-2
Location of the configuration equipment	4-3
Configuration of the control board	4-6
Input type	4-6
Automatic input (external signal)	4-6
Manual input	4-6
Thyristor firing mode	4-7
Frequency	4-7
Configuration of the driver board	4-8

Chapter 5 OPERATION

Thyristor firing modes	5-2
General	5-2
'Phase angle' mode	5-2
'Burst firing' mode	5-3
'Single cycle' mode	5-3
Modulation time	5-4
Soft start / end	5-5
Over-current elimination for the inductive load	5-6
Control	5-7
Control function	5-7
Pulse gating	5-9
Power limit	5-10
Current limit (optional)	5-11
Partial load failure detection	5-12
Retransmission	5-13
Load current image	5-13
Load voltage image	5-13
True power image	5-13
Inhibit and safety quench	5-14

Contents (Continued)

Page

Chapter 6 COMMISSIONING PROCEDURE

Commissioning procedure safety	6-2
Checking the characteristics	6-3
Load current	6-3
Power supply voltage	6-3
Auxiliary supply voltage	6-3
Input signals	6-3
Partial load failure detection	6-3
External thyristor blocks	6-3
Diagnostic unit	6-4
Calibration	6-9
Preliminary settings	6-10
Default position of potentiometer P4	6-11
Resistive load with low resistance variations	6-11
Resistive load with high resistance variations	6-11
Non-saturating inductive load	6-12
Saturating inductive load	6-12
Partial load failure detection setting	6-14
Current limit setting (optional)	6-15
Power limit	6-16
Checks in the event of abnormal operation	6-17

Chapter 7 MAINTENANCE

Thyristor protection	7-2
Thyristor protection fuse	7-3
Replacement of the internal high speed fuse	7-4
Auxiliary power supply protection fuses	7-4
Servicing	7-5
Tools	7-6

Chapter 1

IDENTIFYING THE THYRISTOR UNITS

Contents	page
General introduction to the 470 series	1-2
Technical data	1-6
Power	1-6
Environment	1-6
Control	1-7
Retransmissions	1-8
Current limit	1-8
Power limit	1-8
Partial load failure detection	1-8
Thyristor unit coding	1-9
Backplate	1-10
Short or full code	1-10
Coding example	1-11
470 series thyristor unit and installation parameters	1-11
Thyristor unit coding	1-11
Serial number labels	1-12

Chapter 1 IDENTIFYING THE THYRISTOR UNITS

GENERAL INTRODUCTION TO THE 470 SERIES

The **470** series power thyristor units are **true power controllers** of single-phase industrial electrical loads.

The **470** series is designed for the true power control of:

- inductive and transformer connected loads (transformer primary circuits, in particular) or
- **high** or **low** temperature coefficient resistive loads.

The 470 series is composed of three models:

- **470** : power thyristor unit with incorporated thyristors;
nominal current: **15 A** to **75 A**; natural convection cooling.
- **471** : power thyristor unit with incorporated thyristors;
nominal current: **100 A** to **150 A**; fan cooling.
- **472** : external thyristor driver unit;
nominal current of driven thyristor block up to **4000 A**;
external current transformer (secondary current **5A** nominal).

The nominal line-to-line voltage is **100 V** to **500 V**.

The control signal, which can be reconfigured by the user, can have one of three voltage levels:

0-5 V ; **0-10 V** and **1-5 V**.

or one of four current levels:

0-5 mA ; **0-10 mA** ; **0-20 mA** and **4-20 mA**.

Manual control using external potentiometers is possible.

Three load parameters can be controlled:

true **power (P)**, squared RMS **voltage (V²)**, or squared RMS **current (I²)**.

The **470** series thyristor units are equipped with the following functions:

- different thyristor firing modes
- decrease in the current requirements of high temperature coefficient loads using current limits and soft starts
- elimination of over-currents when starting non-saturating inductive and transformer connected loads
- current limit (optional) and controlled parameter limit
- partial load failure detection
- pulse gating circuit
- inhibit and safety quench
- load current, voltage and power image retransmission.

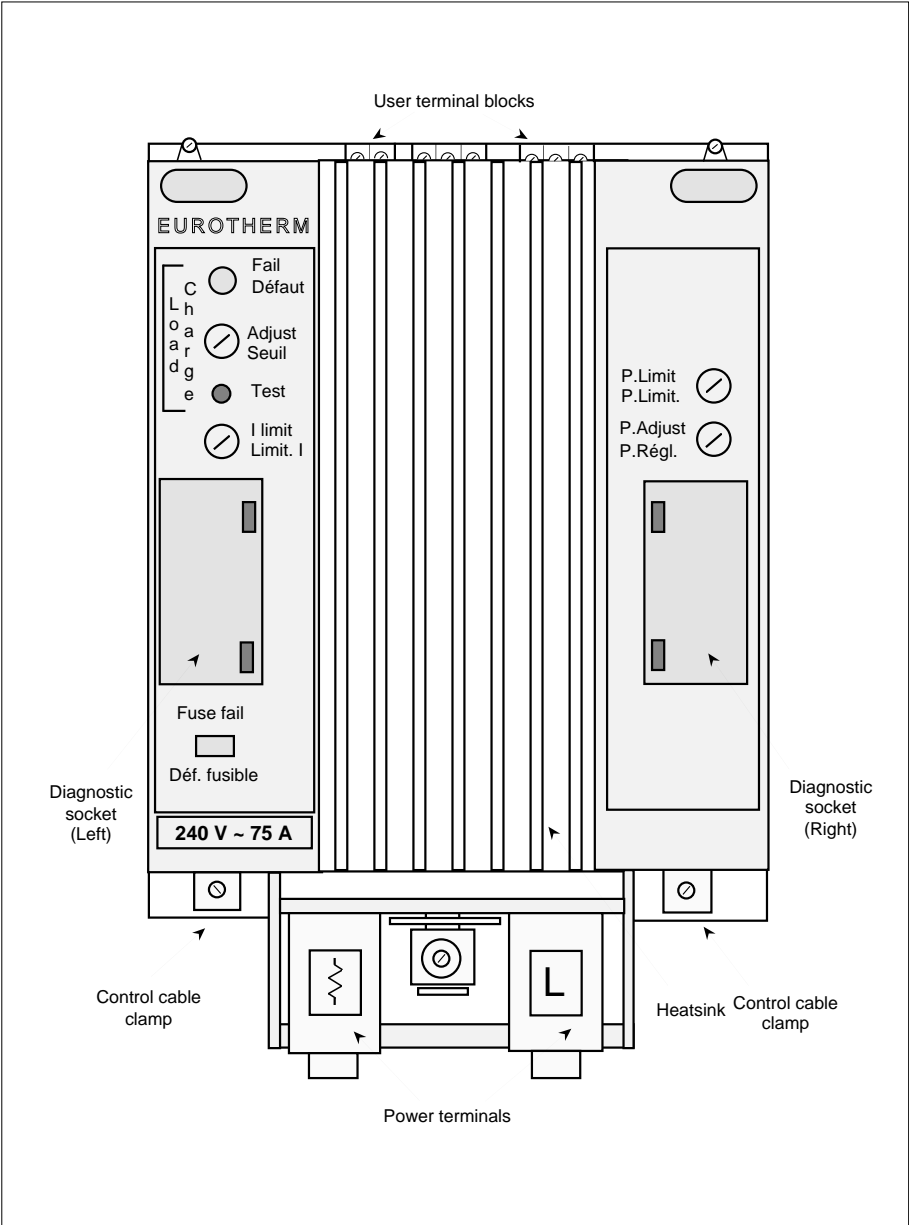

Figure 1-1 Overall view of the 470 series thyristor unit

The **470** series thyristor units are fitted with:

- a '**control board**' which generates the input signals and controls the parameter measured by the driver board;
- a '**driver board**' which controls the true power of the load using the load voltage and current measurements and retransmits the controlled parameter (DC voltage) and the load voltage and current (instant AC values);
for the **472** model, this board generates the external thyristor firing signals;
- a '**neutral board**' to connect the reference neutral or phase (depending on wiring);
- an '**RC snubber board**' which protects the thyristors from fast voltage variations and generates the thyristor firing pulses;
this board has a thyristor **pulse gating** circuit to prevent unstable firing in certain applications.

The control system controls the true power, the squared voltage or the squared load current as a function of an input signal and the selected feedback parameter.

The **soft start** (in thyristor firing angle variation) for high temperature coefficient resistive loads and the **delayed** firing angle at the first half-cycle for the control of inductive and transformer connected loads **minimise transient over-currents**.

The soft start (or end) duration can be set from **0** to **0.25 s** per potentiometer located on the control board.

The **470** series thyristor units are equipped with a power **limit** and, as an option, a current limit (only available in Phase angle firing and Burst firing with soft start modes).

The partial load failure detection circuit (**PLF**) detects a **25 %** increase in the load impedance (independently of the power supply voltage variation).

The partial load failure detection circuit (PLF alarm) is set using a front panel potentiometer for the real current of the load used. The PLF alarm is signalled by the alarm relay **contact** and by the '**Load fail**' indicator light on the front panel.

The **470** thyristor units have the following thyristor **firing** modes:

- thyristor firing angle variation (**'Phase angle'**),
- cyclic firing ratio modulation from 0 to 100 % (**'Burst mode'**).

'Burst mode' firing is characterised by different modes:

- one firing or non-firing cycle (**'Single cycle'**)
- **slow** cycle (modulation time **8 s** at 50% setpoint)
- **fast** cycle (modulation time **0.8 s** at 50% setpoint)
- burst firing (fast or slow) with **soft start** in thyristor firing angle variation
- burst firing (fast or slow) with **soft start and end** in thyristor firing angle variation.

The **front panel** comprises the following:

- the partial load failure detection **setting** potentiometer
- the **'Test'** push button to test the partial load failure alarm setting
- the **indicator light** to display the partial load failure detection
- the **current limit** setting potentiometer (optional)
- the indicator to display an internal thyristor protection fuse blow-out (470 and 471 models)
- the sockets (left and right) for **diagnostics**.
- the **power limit** setting potentiometer
- the **calibration** potentiometer

The **471** model thyristor units are equipped with a fan (**100 A** to **150 A** nominal).

Thermal protection is provided by a thermal switch which detects if the fan has stopped or the heatsink is overheated and inhibits thyristor unit firing.

The **470** thyristor unit is equipped with an **active operation inhibit**.

An external **10 V** voltage (32 V max) or a contact connected to the control terminal block is used to **inhibit** the thyristor unit.

The **470** series thyristor units can be **plugged into** the mounting backplate.

TECHNICAL DATA

The 470 series power thyristor units are designed to control the true power of an industrial single-phase load with a high current requirement at start-up using thyristors.



Caution !

It is the user's responsibility to ensure that the thyristor unit nominal values are compatible with the conditions of installation and operation before commissioning the thyristor unit.

Power

Nominal current	15 A to 150 A (internal thyristors). Up to 4000 A (external thyristor block)
Nominal line-to-line voltage	100 Vac to 500 Vac (+10%,-15%) Inhibit below 70% of the nominal voltage; return to 85 % of the nominal value
Power supply frequency	50 Hz or 60 Hz (± 2 Hz)
Dissipated power	1.3 W (approximately) per ampere (470 and 471 models)
Cooling	Permanent fan cooling above 100 A nominal
Fan	Consumption 23 VA (471 model) Powered by the auxiliary power supply voltage
Thyristor protection	Internal high speed fuse (15 A to 125 A nominal) External fuse for 150 A nominal (471 model) Varistor and RC snubber circuit
Load	Single-phase resistive with high temperature coefficient or nductive or tranformer connected
Residual current	In the OFF state, typically below 30 mA (internal thyristors)
External wiring	To be performed according to the standards IEC 364

Environment

Mounting	In closed metal cabinet
Operating temperature	0°C to +50°C in vertical position in altitude 2000 m maxi
Storage temperature	-10°C to +70°C
Protection	IP00 (can be opened without tools according to IEC 364)
Operating atmosphere	Non-explosive, non-corrosive and non-conducting
Humidity	RH of 5% to 95% without condensation
Pollution	Degree 2 admissible, defined by IEC 664
Electromagnetic compatibility (the product installed and used in accordance with User Manual, see European Directives chapter)	Immunity : comply with Standards EN 61000-4-2 , EN 61000-4-4 , EN 61000-4-3 Radiated emission : comply with EN 55011 Conducted emission : comply with EN 50081-2 (with an external filter), comply with EN 61800-3 (without external filter).
Electrical safety	Comply with Low Voltag Directive 73/23/EEC
CE Mark	The 470 products are CE marked (see European Directives chapter).

Control

Control supply	<p>Connection of the auxiliary power supply to the user terminal block.</p> <p>Consumption: 7 VA (470 and 472 model) 30 VA (471 model)</p>
Signal type	Analogue
Setpoint	Voltage: 0-5 V; 1-5 V or 0-10 V
	Current: 0-5 mA ; 0-10 mA ; 0-20 mA or 4-20 mA
Input impedance	Voltage: > 50 kΩ
	Current: 250 Ω or 1000 Ω (depending on configuration)
Manual control	10 kΩ external potentiometer
Thyristor firing modes	<p>The following can be reconfigured by the user:</p> <ul style="list-style-type: none"> • Phase angle • Single cycle (burst firing with a firing or non-firing cycle) • Fast cycle (typical modulation time at 50 % power : 0.8 s) • Slow cycle (typical modulation time at 50 % power : 8 s) • Fast cycle with adjustable soft start between 0 and 250 ms (with or without soft end) • Slow cycle with adjustable soft start between 0 and 250 ms (with or without soft end)
Transient current elimination	Delayed firing of the 1st burst half-cycle (without soft operation) for non-saturating inductive and transformer connected loads
Enable / Inhibit	<p>Using external contact or external voltage on the control terminal block.</p> <p>Response time: enable 2 s; inhibit < 20 ms</p>
Diagnostics	Two sockets for diagnostic unit used to set and control the thyristor unit using test signals
Load control mode	<ul style="list-style-type: none"> • True power • Squared voltage • Squared current
Wiring	Shielded cable connected to ground at both ends.
Connection	<p>0.5 mm² to 2.5 mm² wires</p> <p>Tightening 0.7 N.m</p> <p>The control terminals are isolated from the power and the load circuit.</p>

Retransmissions

- Signal outputs
- **Instant load current.**
Rectified full wave signal (0 to 2.5 V mean) proportional to the real load current image.
 - True **power** (0 - 10 Vdc)
 - Load **current** (0 - 2.5 Vac)
 - Load **voltage** (0 - 2.5 Vac)

Current limit (optional)

- Threshold limit
- Maximum load current limit.
Setting using potentiometer on front panel.
Setting possible using an external potentiometer or an external voltage.
- Availability
- In 'Phase angle' and 'Burst firing with soft start' modes.

Power limit

- Threshold limit
- Limit of controlled parameter by the control system (true power, squared voltage or load current)
Setting using potentiometer on front panel.
Setting possible using an external potentiometer or an external voltage.

Partial load failure detection

- Alarm
- 20%** current decrease detection.
Setting on front panel using '**Adjust/Seuil**' potentiometer.
- Operation test
- Using '**Test**' push button on front panel.
- Signalling
- 'Load Fail'** indicator light on the front panel.
Alarm relay contact **open** in alarm state (in **standard** version)
Contact **closed** in alarm state (optional)

Caution !



Due to the continual improvement of products, Eurotherm may be required to modify specifications without prior notice. For any further information and in the event of doubt, contact your Eurotherm Office.

THYRISTOR UNIT CODING

Model	/	Nominal voltage	/	Auxiliary power supply	/	Nominal current	/	Input signal	/	Firing mode	/	Control mode	/	Options	/	End	00
-------	---	-----------------	---	------------------------	---	-----------------	---	--------------	---	-------------	---	--------------	---	---------	---	-----	----

Model	Code
Thyristor unit:	
470 (75 A max)	470/113
471 (125 A max)	471/117
471 (150 A max)	471/100
Driver for external thyristors	
472	472/000

Nominal voltage	Code
100 V	26
110 V	10
115 V	51
120 V	24
200 V	27
220 V	12
230 V	52
240 V	13
277 V	32
380 V	22
400 V	53
415 V	23
440 V	28
480 V	15
500 V	29

Auxiliary power supply	Code
100 V and 230 V	41
115 V and 230 V	19
200 V and 230 V	42
277 V and 230 V	46
380 V, 400 V, 415 V and 230 V	43
440 V and 230 V	47
480 V, 500 V and 230 V	44

Nominal current	Code
470 model: 15 A	081
25 A	082
40 A	083
55 A	062
75 A	113
471 model: 100 A	114
125 A	117
150 A	100
472 model: external thyristors	000

Input signal	Code
0-5 V	008
1-5 V	068
0-10 V	060
0-5 mA	069
0-10 mA	071
0-20 mA	072
4-20 mA	073

Thyristor firing mode	Code
Phase angle	002
Single cycle	160
Fast cycle (0.8 s)	001
Fast cycle	
with soft start	055
Fast cycle	
with soft start and end	SDF
Slow cycle (8 s)	050
Slow cycle	
with soft start	056
Slow cycle	
with soft start and end	SDS

Control mode	Code
True power	28
Squared load voltage	26
Squared load current	29

Options	Code
Current limit	
(available in Phase angle	
and soft start)	55
Frequency 60 Hz	69
PLF alarm contact	
closed in alarm state	83
No backplate	76

Backplate

Thyristor unit model / Nominal current / Backplate code / 00

For advance installation, order the mounting backplate without a unit.

Thyristor unit model	Nominal current	Backplate code
470	15 A to 75 A	LA 171569
471	100 A to 150 A	LA 171570
472	External thyristors	LA 171615

For deferred orders of units with no backplates (pre-installed backplates), use the thyristor unit coding option 'No backplate' - code **76**.

Short or full code

The full code for the **470** series thyristor units (shown on page 1-9 in 'Coding') specifies all the technical characteristics selected by the client.

To simplify the process for ordering thyristor units, the '**short**' code can be used, specifying the model, the nominal current and the operating voltage.

The 'short' code is presented as follows.

Model / Nominal current / Nominal voltage / Auxiliary supply voltage / 00

If the 'short' code is used, the **470** thyristor unit is supplied with the standard configuration:

- the input configured for 4-20 mA
- the thyristor firing mode: firing angle variation (Phase angle)
- frequency 50 Hz
- the delayed thyristor firing potentiometer is set for the 90° delay (inductive and transformer connected load) and for the maximum start ramp (resistive load).

CODING EXAMPLE

470 series thyristor unit and installation parameters

Nominal load current	45 amperes
Nominal power supply voltage	380 volts line-to-line, 50 Hz
Auxiliary supply voltage	380 volts
Input signal	0 - 10 volts
Firing mode	'Fast cycle' burst mode firing with soft start.
Control mode	True power
Options:	<ul style="list-style-type: none"> • Current limit • 'Partial load failure detection' alarm relay contact closed in alarm state • No backplate.

Thyristor unit coding

470 / 113 / 22 / 43 / 062 / 060 / 055 / 28 / 55 / 83 / 76 / 00

Caution !



The nominal voltage of the **470** series thyristor unit must correspond to the power supply voltage used to prevent problems of **non-operation** for voltages **lower than 70%** of the nominal voltage (inhibit below **70%** of the nominal voltage, response time <10 ms; automatic reset 2 s after return to **85 %** of the nominal value).

To obtain optimum control, the nominal current of the thyristor unit must be as close as possible (slightly above) the real load current.

SERIAL NUMBER LABELS

An **identification** label (specifying the **coding** of the thyristor unit) and two **configuration** labels give all the information relating to the factory settings of the thyristor unit.

The identification label is **externally** located at the top of the right-hand side panel of the unit.

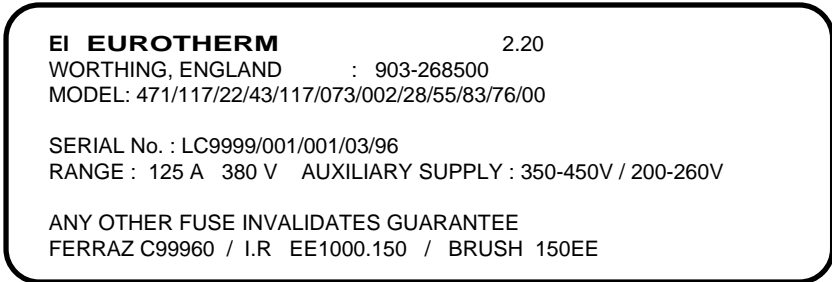

Figure 1-2 Example of an identification label for a 471 model thyristor unit
 The information corresponds to nominal current 125 A, nominal voltage 380 V, auxiliary supply in the range 350 to 450 V, 4-20 mA input, 'phase angle' firing with 'power' feedback, current limit available, PLF alarm contact closed in alarm state, unit delivered with no backplate.

The configuration labels present the factory settings.

The standard configuration (4-20 mA input, 'Phase angle' firing mode and frequency 50 Hz) is shown on one of the configuration labels.

If the configuration is different from the standard, it is shown in the appropriate boxes.

In this case, the position of the configuration mini-switches for the selected input signal and firing mode are shown.

The second configuration label shows the selection of the feedback mode using mini-switches.

The information on the configuration labels is shown in French and in English.

Caution !



Any reconfiguration done by the user will render obsolete the original in-house configuration code shown on the label.

Chapter 2

INSTALLATION

Contents	page
Safety during installation	2-2
Dimensions	2-3
Mechanical mounting	2-4

Chapter 2 INSTALLATION

SAFETY DURING INSTALLATION



Warning !

470 units must be installed by a person authorised to work in an industrial low voltage electrical environment.

Units must be installed in bulkhead mountings in fan-cooled electric cabinets, guaranteeing the absence of condensation and pollution.

The cabinet must be closed and connected to the safety ground in accordance with the standards NFC 15-100, IEC 364 or the current national standards.

For installations in fan-cooled cabinets, it is recommended to place a fan failure detection device or a thermal safety control in the cabinet.

The units must be mounted with the heatsink positioned vertically and with no obstructions either above or below which could block the passage of the ventilation air.

If multiple units are installed in the same cabinet, they should be arranged in such a way that the air from one unit cannot be admitted into the unit located above it.

Leave a vertical gap of at least **80 mm** between two units.

Leave a gap of at least **20 mm** between two units installed side by side.

The external thyristors controlled by a **472** driver unit must be at least **50 cm** from the 472 unit.



Caution !

The units are designed to be used at an ambient temperature less than or equal to **50°C**.

Excessive overheating may cause incorrect operation of the unit, which in turn may cause damage in the components.

471 series power thyristor units have **permanent** fan cooling.

DIMENSIONS

The dimensions of the 470 series thyristor units are given in figure 2-1 and table 2-1.

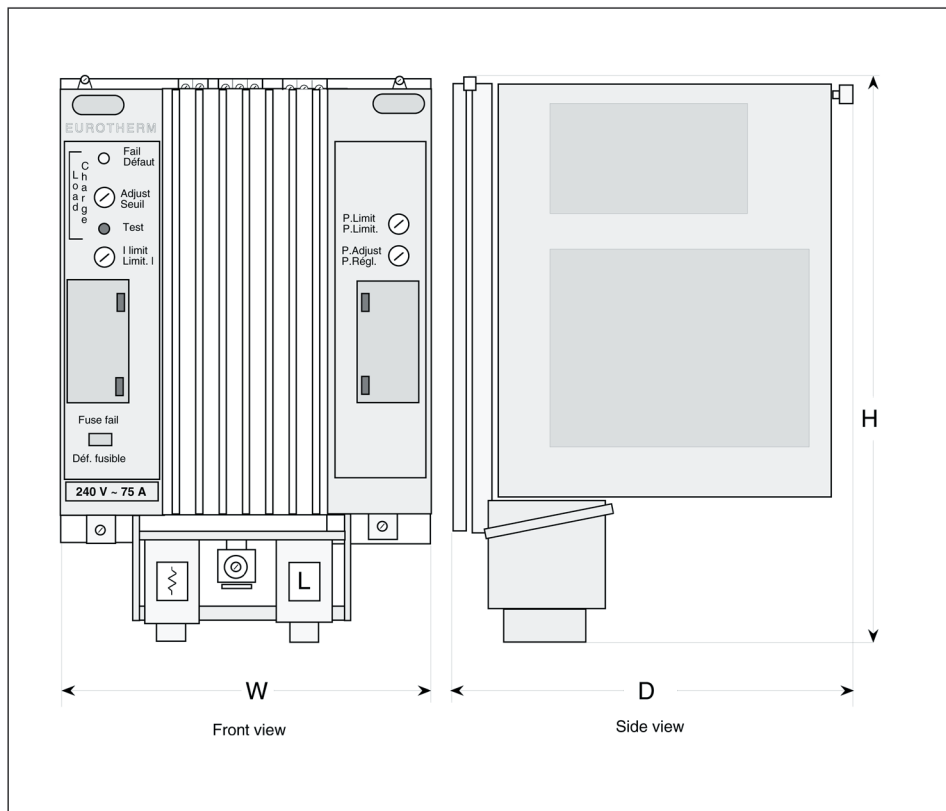

Figure 2-1 Overall dimensions

Model	Height (H) mm	Width (W) mm	Depth (D) mm	Weight kg
470	249	170	236	3.5
471	282	170	236	5
472	249	115	236	2.5

Table 2-1 Overall dimensions and weight

MECHANICAL MOUNTING

470 series units are plugged into a steel backplate located at the rear of the unit.

The backplate can be mounted:

- on a pair of asymmetric DIN rails
- on a vertical wall.

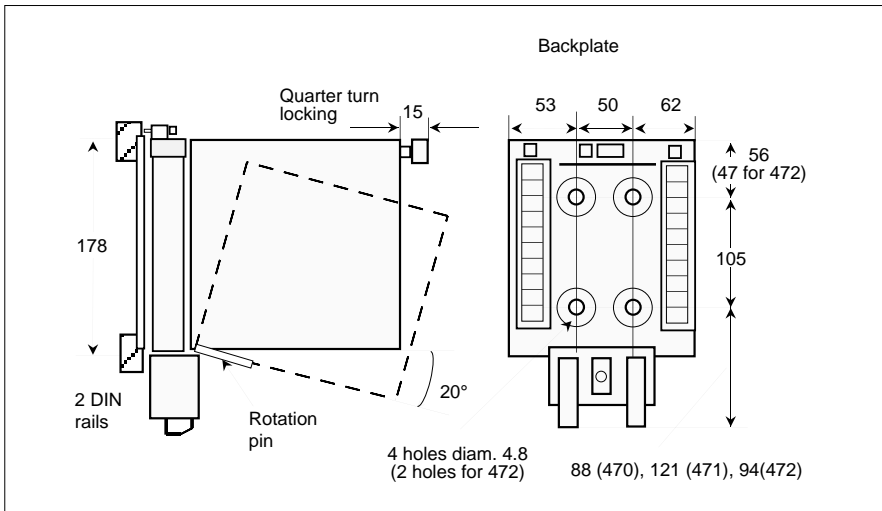

Figure 2-2 Dimensions for attachment to a vertical wall (mm)

To **mount** the unit:

- tilt the unit forwards to approximately 20 degrees from the horizontal
- fit the rotation pin into the slot in the backplate
- raise the unit to the horizontal
- lock by a quarter of a turn.

To **dismount** the unit:

- unlock the upper attachment by a quarter of a turn
- tilt the unit forwards to approximately 20 degrees from the horizontal
- free the unit from its backplate.

Warning !



Before dismantling the unit, ensure that it is switched off and that the heatsink is not hot.

Before dismantling the backplate, ensure that it is isolated from the power supply.

Chapter 5

OPERATION

Contents	page
Thyristor firing modes	5-2
General	5-2
'Phase angle' mode	5-2
'Burst firing' mode	5-3
'Single cycle' mode	5-3
Modulation time	5-4
Soft start / end	5-5
Over-current elimination for the inductive load	5-6
Control	5-7
Control function	5-7
Pulse gating	5-9
Power limit	5-10
Current limit (optional)	5-11
Partial load failure detection	5-12
Retransmission	5-13
Load current image	5-13
Load voltage image	5-13
True power image	5-13
Inhibit and safety quench	5-14

Chapter 3

WIRING

Contents	page
Safety during wiring	3-2
Fixing the power cables	3-3
User terminal blocks	3-5
Auxiliary power supply	3-6
Alarm relay contact	3-7
Load voltage information	3-8
Control cables	3-9
Fixing	3-9
Connecting the shield to the ground	3-10
Control terminal block	3-11
Driver terminal block	3-13
Input signals	3-14
Safety quench	3-14
Inhibit	3-14
External control connection	3-15
Control of multiple thyristor units	3-16
Parallel input connection	3-16
Serial input connection	3-16
Manual control connection	3-17
Current limit connection (optional)	3-18
Limit set using the potentiometer on the front panel	3-18
Limit set using an external voltage	3-19
Limit set using an external potentiometer	3-20
Power limit connection	3-21
Limit set using the potentiometer on the front panel	3-21
Limit set using an external potentiometer	3-22
Limit set using an external voltage	3-22
Retransmission signals	3-23
External thyristor block control (472 model)	3-24
Examples of wiring diagrams	3-26
470 and 471 model thyristor units	3-26
Driver unit, 472 model	3-28

Chapter 3 WIRING

SAFETY DURING WIRING

Warning !



Wiring must be performed by personnel who are qualified to work with low voltage electrical equipment. It is the user's responsibility to wire and protect the installation in accordance with current professional standards.

A suitable device guaranteeing electrical separation of the equipment and the power supply must be installed upstream from the unit in order to perform the operation in complete safety.

All power and control connections are made to the terminal blocks located on the mounting backplate and must be made without a unit present.



Warning !

Before any connection or disconnection, make sure that the power and control cables and wires are isolated from the voltage sources.

For safety reasons, the safety earth cable must be connected before any other connection during wiring and must be the last cable to be disconnected.

The **safety earth** is connected to the screw located on the strip provided for this purpose in the lower part of the unit, behind the power terminals and labelled as follows:



Caution !



To ensure that the 470 unit is grounded correctly, make sure that it is attached to the **reference ground plane** (panel or bulkhead). If this is not the case it is necessary to add a ground connection **no more than 10 cm** long between the earth connection and the reference ground plane.

Warning !



The purpose of this connection is to guarantee correct **ground continuity**. It is **not**, in any circumstances, a **substitute** for the **safety earth** connection.

FIXING THE POWER CABLES

The external **wiring** is performed at the front to the terminal blocks on the backplate, once the backplate has been fixed, with the unit disconnected.

For the **470** and **471** models, the power cables are attached to the power terminal blocks marked **L' (Line)** and **L'' (Load)** located on the lower part of the unit.

The power and earth cables are connected to **tunnel** terminal blocks (**470** model) or **screw** terminals (**471** model).

Above **125 A**, it is necessary to connect the power cables using round lugs.

The capacities of the power terminals are shown in table 3-1.

The **tightening torques** must comply with the values shown in the same table.

Caution !



Tighten the power connections correctly.

Poor tightening can lead to incorrect operation of the thyristor unit and can have serious consequences on the installation.

Nominal current	Capacity of the power and earth terminals mm ²	Tightening torque N.m
15 A to 75 A 470 model	2.5 to 50	2.5
100 A to 150 A 471 model	Power: 50 or 70 Earth: 25 to 50	10 2.5
472 model	–	–

Table 3-1 Details of power wiring for the 470 series

Note: Since the 472 units are electronic driver units, they do not contain power terminal blocks.

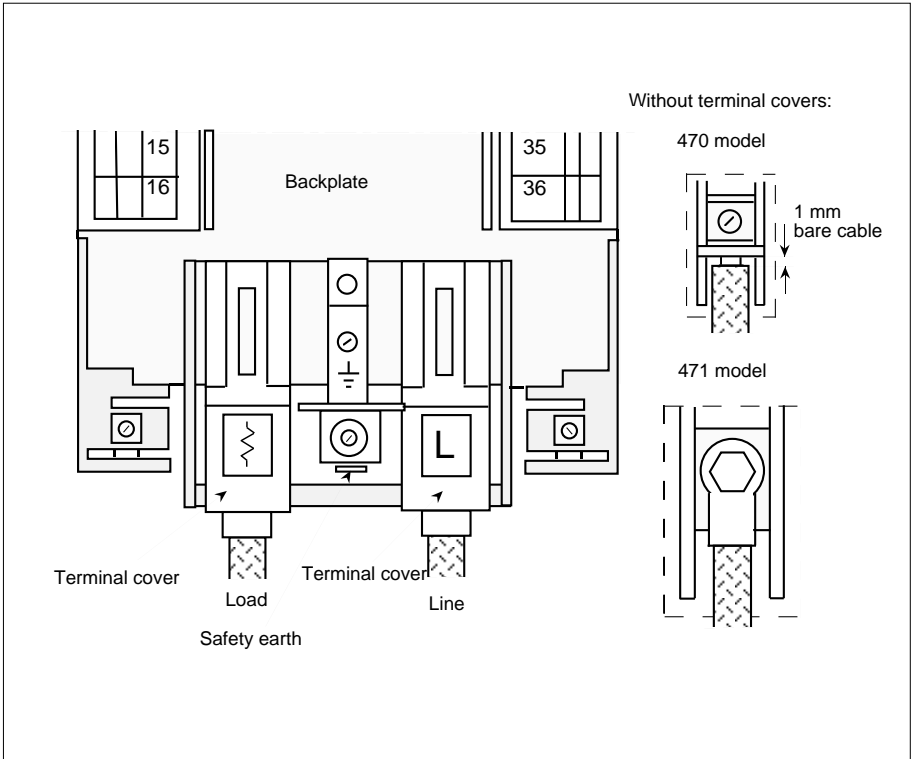

Figure 3-1 Power and safety earth cable fixing points

The cross-section of the connecting conductors used must comply with the **IEC 943** standard.

Model	Fixing	Distance between terminals mm
470	35 mm ² tunnel terminal	55
471	M10 Screw	61.5

Table 3-2 Power wiring details for the 470 series

USER TERMINAL BLOCKS

The user terminal blocks are located at the top left of the backplate.

They are used to connect:

- the auxiliary power supply,
- the PLF alarm relay contact,
- the load voltage (for control).

The unit must be unplugged from the backplate in order to access the user terminal blocks.

The connections are made using screw terminal blocks; terminal tightening torque: **0,7 N.m.**

The maximum wire cross-section is **2.5 mm²**.

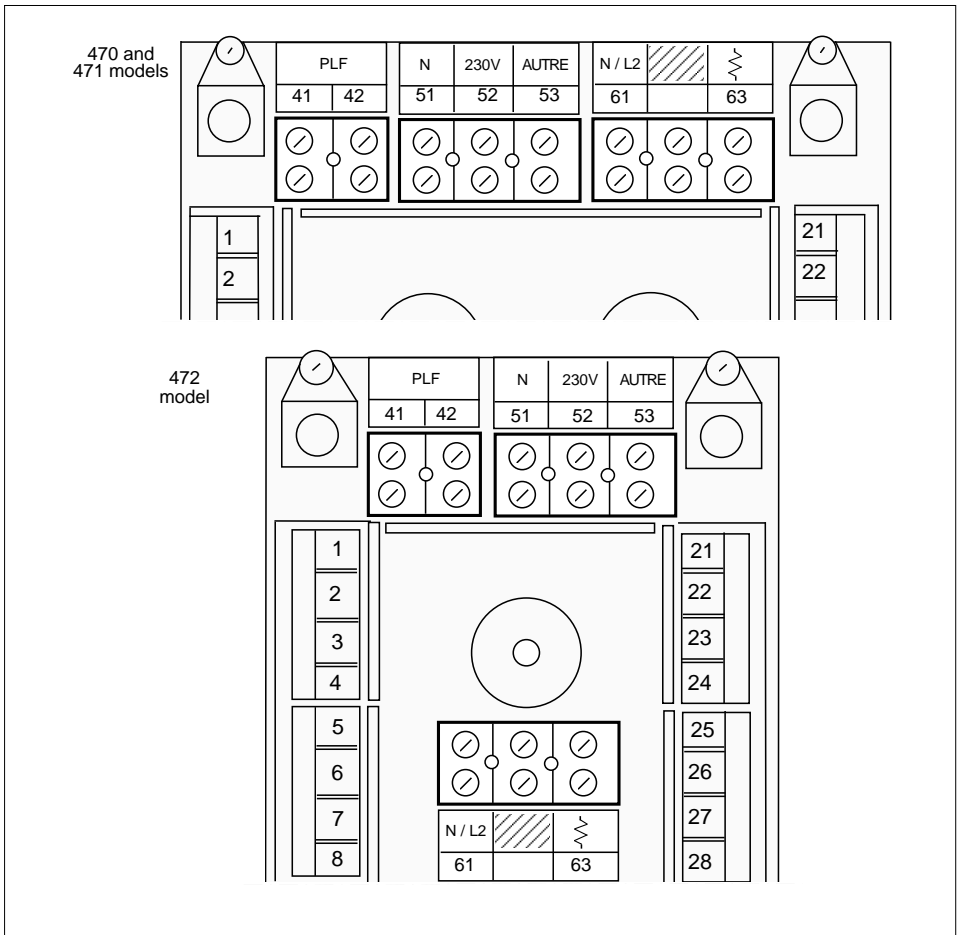

Figure 3-2 User terminal blocks

Auxiliary power supply

The auxiliary power supply powers the following:

- the electronic control
- the fan (for fan-cooled units)
- the partial load failure detection circuit.

Terminals **51** and **52** are used when the electronic control circuit is powered at **230 V** (in the voltage range 200 V to 260 V).

Terminals **51** and **53** are used for voltages **outside** the range 200-260 V (110 or 400 V, for example).

Terminal **51** is the reference phase or neutral.

The auxiliary power supply voltage is specified in the unit code (see page 1-9).

Caution !



- The phases arriving on terminals **51** to **53** must be identical to those on the unit's power terminals, especially if several units are distributed amongst several phases of a three-phase power supply.
 - The order of connection must be observed.
 - The control must be powered up after or at the same time as the power.
 - The control must be powered down before or at the same time as the power.
-

The auxiliary power supply is protected from the electrical disturbances on the power supply in common mode.

Caution !



- Each connection wire from the auxiliary power supply **to a phase** must be protected by a **1 A fuse**.
-

Alarm relay contact

The connection of the partial load failure detection relay contact (**PLF** alarm) which signals the active alarm state is made on the user terminal block located in the upper part of the thyristor unit, **on the left**.

The contact output terminals are marked **41** and **42** on the terminal block label.

The PLF alarm relay is **de-energised in the alarm state** (and when the unit is switched off).

On **standard** models, the relay contact available between terminals **41** and **42** is **open** in the alarm state and in the event of a power failure.

Optionally (code **83**), the alarm relay contact is **closed** in the alarm state.

The partial load failure detection relay contact is protected against disturbances by an **RC snubber** circuit on the control board.

The alarm contact cutoff capacity is **0.25 A** under **250 Vac** or **30 Vdc**.
The contact cutoff voltage must not exceed **250 Vac** in any circumstances.

The PLF alarm relay contact output is suitable for driving an alarm unit.

The PLF alarm relay is acknowledged either by switching off the thyristor unit or by a return to the nominal current.

Load voltage information

The **470** series power units and driver units use the **load voltage** information to perform **true power** control.

The load voltage measurement is connected to terminals **61** and **63** on the user terminal block.

Terminal **61** must be connected to the 'Load' - 'Neutral or Phase 2' common point.

Terminal **63** must be connected to the 'Load' - $\left\{ \begin{array}{l} \text{terminal or} \\ \text{external thyristor} \end{array} \right\}$ common point.

Caution !



The order of connection must be observed, otherwise, the power measured could be negative and cause the control to malfunction.

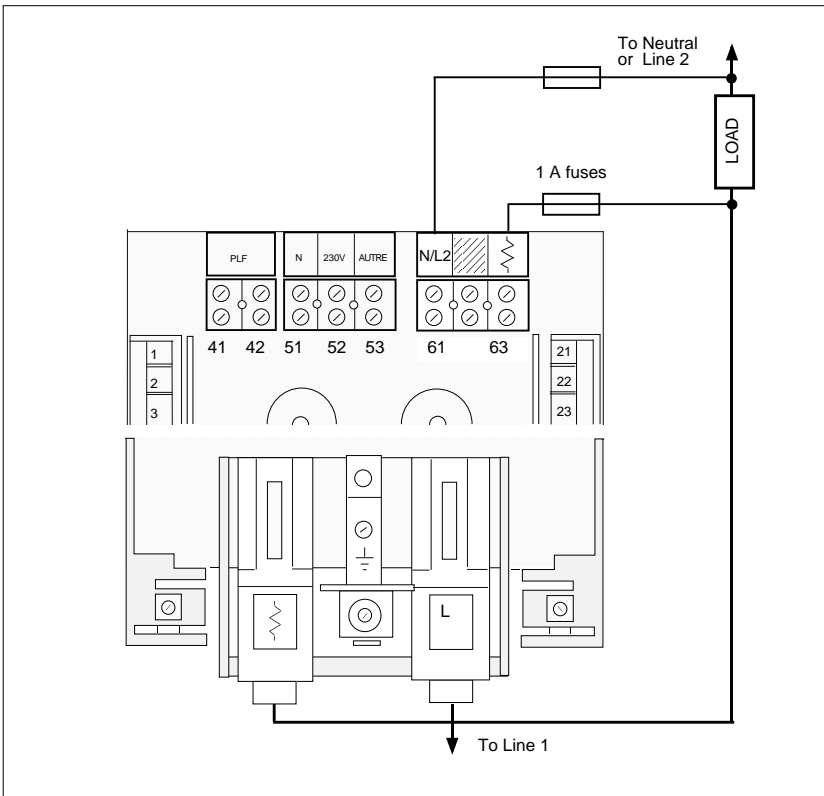

Figure 3-3 Load voltage connection (example for 470 and 471 models)

CONTROL CABLES

Caution !



The control connections must be made with **shielded cables connected to earth at both ends** in order to ensure satisfactory immunity against interference.

Separate the control cables from the power cables in the cable trays.

Fixing

The control wires must be grouped together in a shielded cable passing through the **cable clamp** under the unit, to the left of the power terminal block.

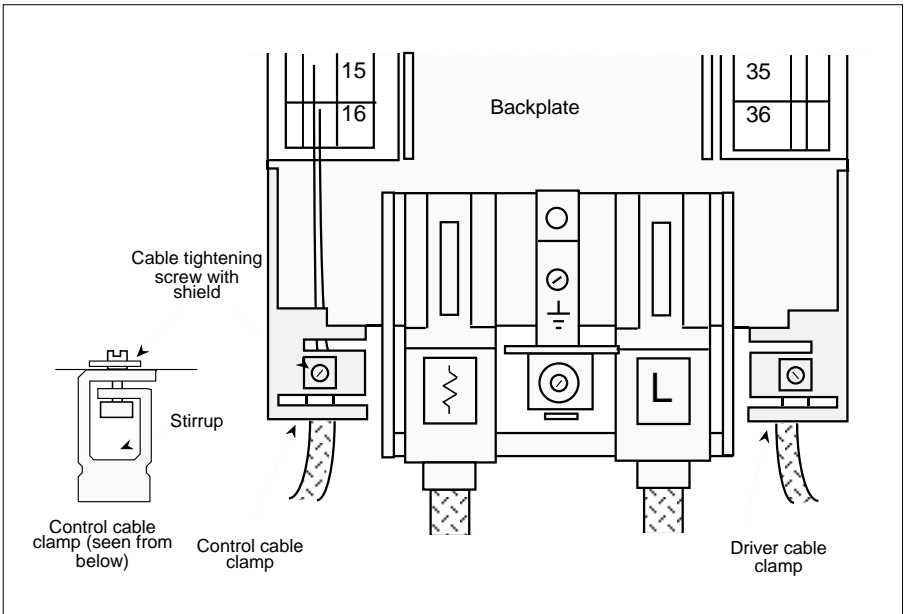

Figure 3-4 Control cable clamp location

Important !

To facilitate the earthing of the cable shield and to ensure maximum immunity against electromagnetic interference, the **metal** cable clamp is **fixed directly to the ground** of the unit.

Connecting the shield to the ground

To **insert** the control cable and **ground** its shield:

- **Strip** the shielded cable as shown in figure 3-5,a.

The control wires must be long enough for the connection between the metal cable clamp and the control terminal block. The wiring inside the unit must be as short as possible.

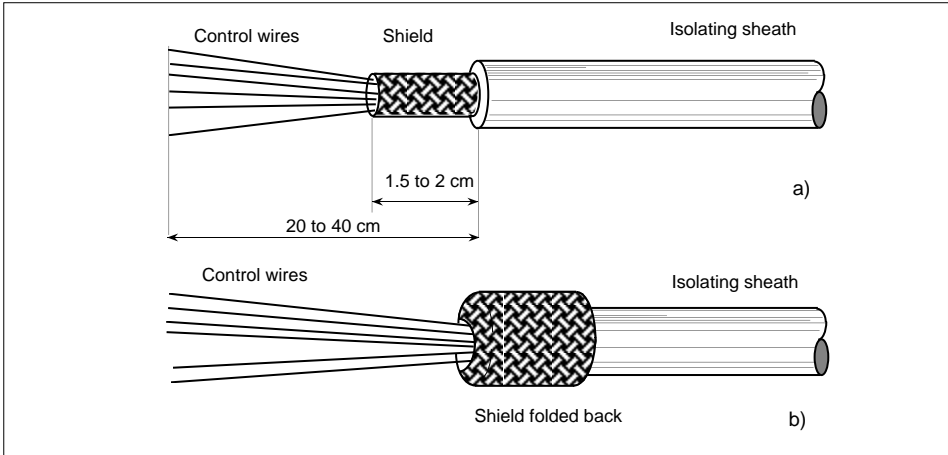

Figure 3-5 Control cable stripping

- **Fold back** the shield on the isolating sheath (figure 3-4,b).
- **Insert** the cable in the metal cable clamp so that the shield is located in the stirrup and does not pass the cable clamp.
- **Tighten** the stirrup (3.5 x 1 flat screwdriver; tightening: **0.7 N.m.**).

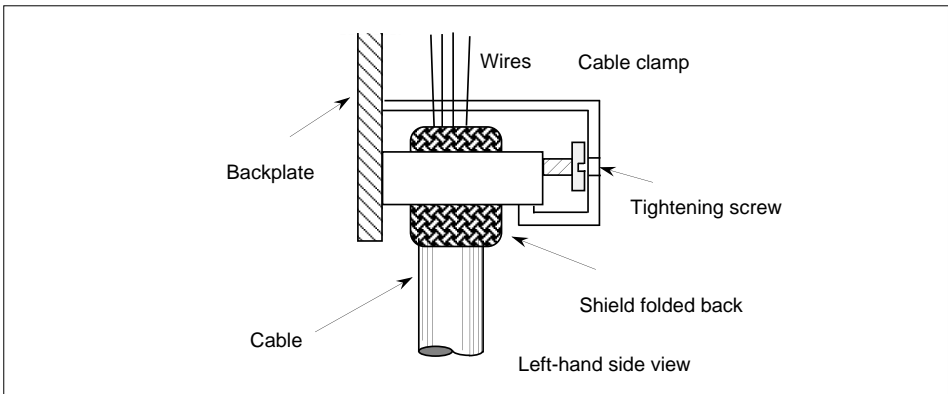

Figure 3-6 Cable tightening and shield grounding

The possible diameter of the cables with the shield folded back is **5 to 10 mm** per cable clamp.

CONTROL TERMINAL BLOCK

The following connections are made on the control board user terminal block:

- the (external or manual) input signal
- the thyristor unit operation inhibit
- the threshold current limit
- the load current retransmission.

The control terminal block is fixed on the backplate and can be accessed after the 470 thyristor unit has been unplugged.



Warning !

Dangerous live parts may be accessible when the unit is unplugged.

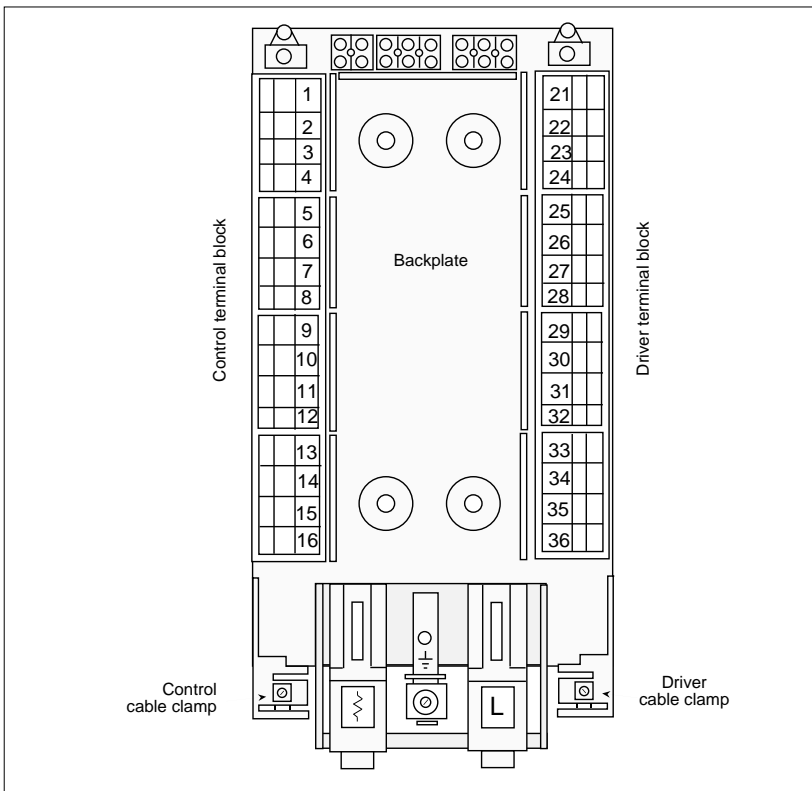

Figure 3-7 470 thyristor unit control and driver terminal labelling

Control terminal block capacity: **0.5 mm² to 2.5 mm².**

Control terminal tightening: **0.7 N.m.**

Terminal number	Assignment
1	Not connected
2	
3	Load current image output Retransmission 0-2.5 V Full wave rectified signal
4	Manual input
5	External input
6	Common 0 V
7	Not connected
8	
9	
10	
11	
12	+10 V user voltage
13	Not used
14	Current limit input
15	Not used
16	Thyristor unit operation inhibit input

Table 3-3 Control terminal identification

DRIVER TERMINAL BLOCK

The following connections are made on the driver board user terminal block:

- the safety quench connection
- the load voltage signal
- the power limit signal
- the retransmission signals.

On the **472** model only, the external thyristor firing signals and the current information are also connected to the driver terminal block.

The driver terminal block is fixed on the backplate and can be accessed after the 470 thyristor unit has been unplugged (see figure 3-7).



Warning !

Dangerous live parts may be accessible when the unit is unplugged.

Control terminal block capacity: **0.5 mm² to 2.5 mm².**

Control terminal tightening: **0.7 N.m.**

Terminal number	Assignment
21 and 22	Safety quench
23 (for 472)	External thyristor 1 cathode
24 (for 472)	External thyristor 1 gate
25	Not used
26 (for 472)	External thyristor 2 cathode
27 (for 472)	External thyristor 2 gate
28 to 32	Not connected
33	0 - 2.5 Vac load voltage image output
34	0 - 2.5 Vac load current image output
35	Controlled parameter limit input
36	0 - 10 Vdc controlled parameter retransmission
37 and 38 (for 472)	External thyristor load current signal input

Table 3-4 Terminal identification on the driver board terminal block

For the **470** and **471** models, the terminal numbers on the driver terminal block are **21 to 36**.

For the **472** model, the terminal numbers on the driver terminal block are **21 to 40**.

INPUT SIGNALS

The control wires are connected to the screw terminals on the control terminal block attached to the backplate. The control terminal block is accessible with the thyristor unit dismantled from the backplate.

To dismantle the thyristor unit from its backplate:

- unlock the upper attachment by a quarter of a turn
- tilt the unit forwards to approximately 20 degrees from the horizontal
- free the unit from its backplate.

Warning !



- Before dismantling the unit, ensure that the heatsink is not hot.
- Dangerous live parts may be accessible if the unit is dismantled when the thyristor unit is switched on.

The thyristor units can be controlled by an **external analogue** signal (from a controller or another signal source) or **manually** by an external potentiometer connected to the control terminal block.

Important !

The control inputs are **isolated** by transformers from the auxiliary supply voltage and from the power section.

Safety quench

If the unit is unplugged from its backplate, the operation of the thyristor unit is stopped.

Terminals **21** and **22** on the driver terminal block (which must be **connected together**) are the first two terminals to be disconnected from the backplate, which instantly (**10 ms** maximum) causes the thyristor unit output power to be reset.

Inhibit

Inhibit indicates that thyristor firing is not possible irrespective of the control signal. The inhibit is effective when a DC voltage is set on terminal **16**.

The inhibit voltage must be between **4 V** and **32 V** with reference to terminal **6** ('0 V').

Firing can be inhibited by connecting terminal **16** to terminal **12** ('+10 V') on the same control terminal block. To deactivate the inhibit, simply do not connect terminal **16** or set it to a DC voltage between **-2 V** and **1 V**.

External control connection

The external signal is applied to terminals **5** and **6** of the control terminal block ('+' on terminal 5).

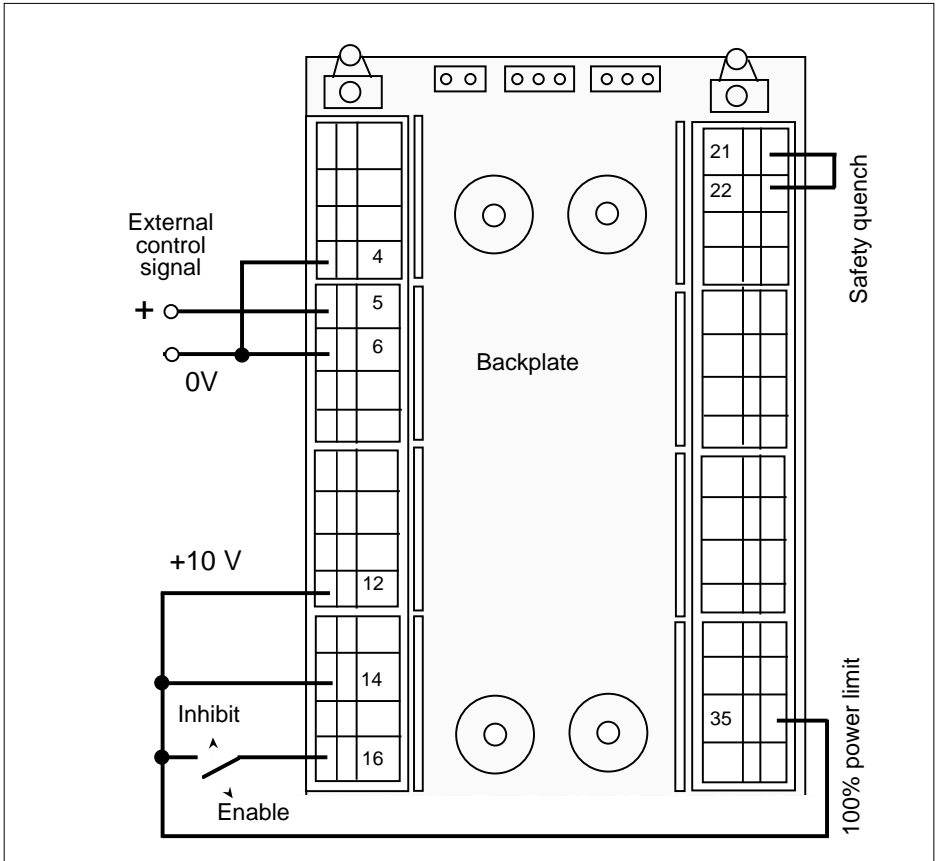

Figure 3-8 External control signal connection

For normal operation of the **470** series thyristor unit with the external control:

- disconnect the 'Inhibit' input (terminal **16**) from the '+10 V' voltage (terminal **12**)
- terminal **14** ('Current limit' option) should be connected to terminal **12** ('+10 V')
- the 'Manual input' (terminal **4**) should be connected to terminal **6** ('0 V')
- the 'Power limit' input (terminal **35**) should be connected to terminal **12** ('+10 V')
- short-circuit terminals **21** and **22** ('Safety quench').

Control of multiple thyristor units

If multiple thyristor units are controlled by the same controller, the inputs can be connected in **parallel** or in **series**.

All the thyristor units must be **configured** for the **same** thyristor firing mode and for the **same** input signal.

Parallel input connection

The inputs must be configured for voltage.

The input impedance for each thyristor unit is **50 k Ω** .

The current required for each thyristor unit is **0.2 mA** at full scale.

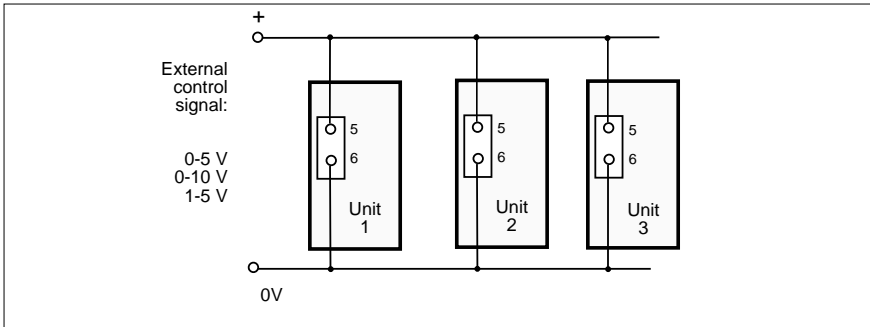

Figure 3-9 Parallel input connection

Serial input connection

The inputs must be configured for current.

The input impedance when configured for **0-10 mA** or **0-5 mA** is **1 k Ω** .

For **0-20 mA** and **4-20 mA** inputs, the input impedance is **250 Ω** .

At full scale, a voltage of **5 V** is needed for each thyristor unit for the **0-20 mA** and **4-20 mA** inputs (**10 V** for the **0-10 mA** or **0-5 mA** input).

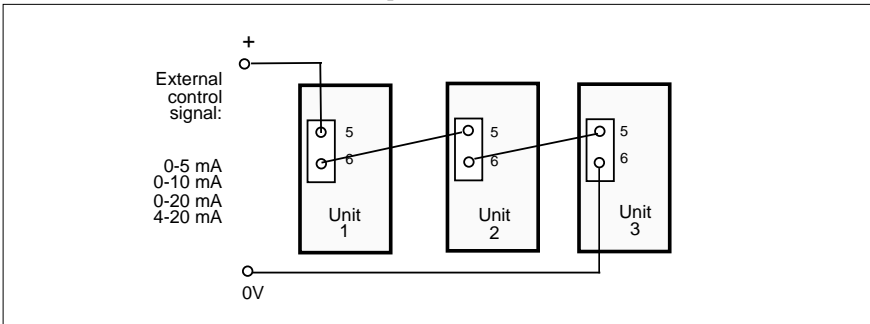

Figure 3-10 Serial input connection

Manual control connection

The **470** series unit can be controlled by an external potentiometer (**manual control**). For manual control, the external potentiometer should be connected between terminals **6** (**0 V**) and **12** (**+10 V**). The wiper is connected to terminal **4** ('Manual input'). The potentiometers used are from **4.5 k Ω** to **10 k Ω** .

For manual control, the **470** series unit should be configured for voltage.

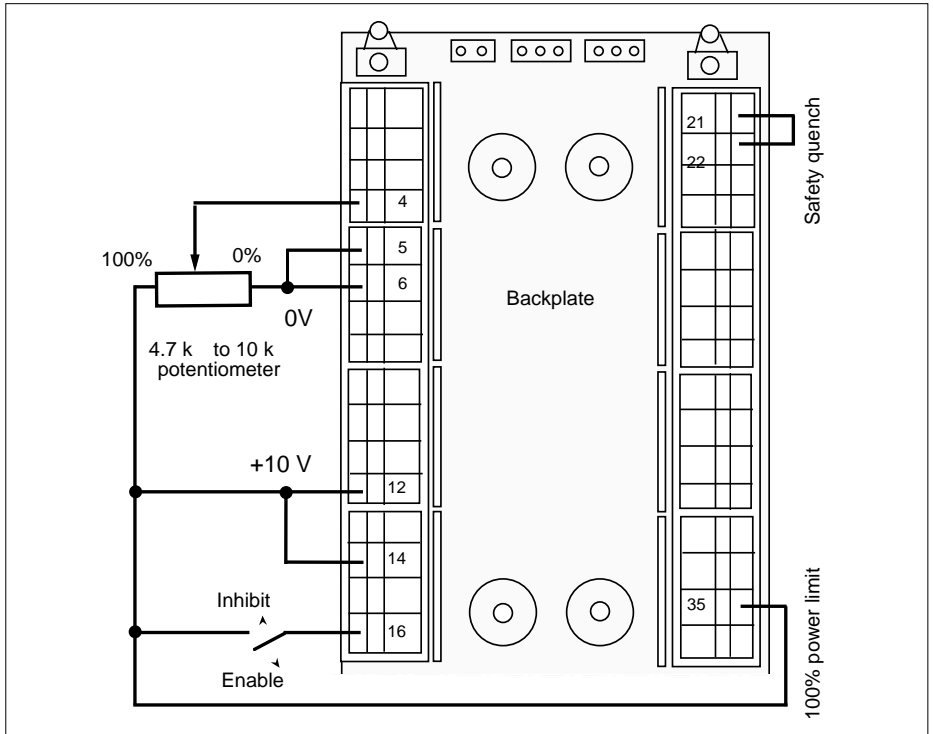

Figure 3-11 470 thyristor unit manual input

If manual control is used, terminal **5** of the external input must be connected to **'0 V'**.

Caution !



If the input signal is connected to terminal **5**, the **two** signals (external and manual) are added together.

The inhibit circuit should be open (terminal **16** is not connected to terminal **12**). Terminals **14** ('Current limit' option), **35** ('Power limit') and **12** ('+10 V') should be connected. Terminals **21** and **22** ('Safety quench') should be connected.

Current limit connection (optional)

The **470** series thyristor units have the **threshold** current limit as an option.

The current limit is only available in the 'Phase angle' and 'Burst firing with soft start' firing modes.

The threshold current limit is a function which is used to limit the load current to a **specified value**, independently from the input signal.

The current limit controls the **squared** RMS load current (I^2).

The current limit can be used with an external or manual control.

The current limit threshold can be set:

- by the potentiometer marked '**I limit / Limit. I**' on the front panel,
- by an external voltage in cascade with the potentiometer on the front panel,
- by an external potentiometer in cascade with the potentiometer on the front panel.

Limit set using the potentiometer on the front panel

The '**I limit / Limit. I**' potentiometer on the front panel is powered by the **+10 V** internal voltage (terminal **14** on the control terminal block should be connected to terminal **12**).

If the '**I limit / Limit. I**' potentiometer is turned completely **clockwise**, the current value is limited to **110%** of the nominal thyristor unit current value.

When this potentiometer is turned **anti-clockwise**, the maximum current falls to **0**.

Caution !



If the adjustable limit is not used in the 'Current limit' option, it is nonetheless necessary to connect terminals **14** and **12**. Otherwise, the current limit is at zero and the thyristor unit cannot output.

Limit set using an external voltage

To set the current limit threshold using an external voltage, a **0-10 V** voltage should be connected between terminals **14** ('Current limit') and **6** ('0 V'), terminal **14** is positive.

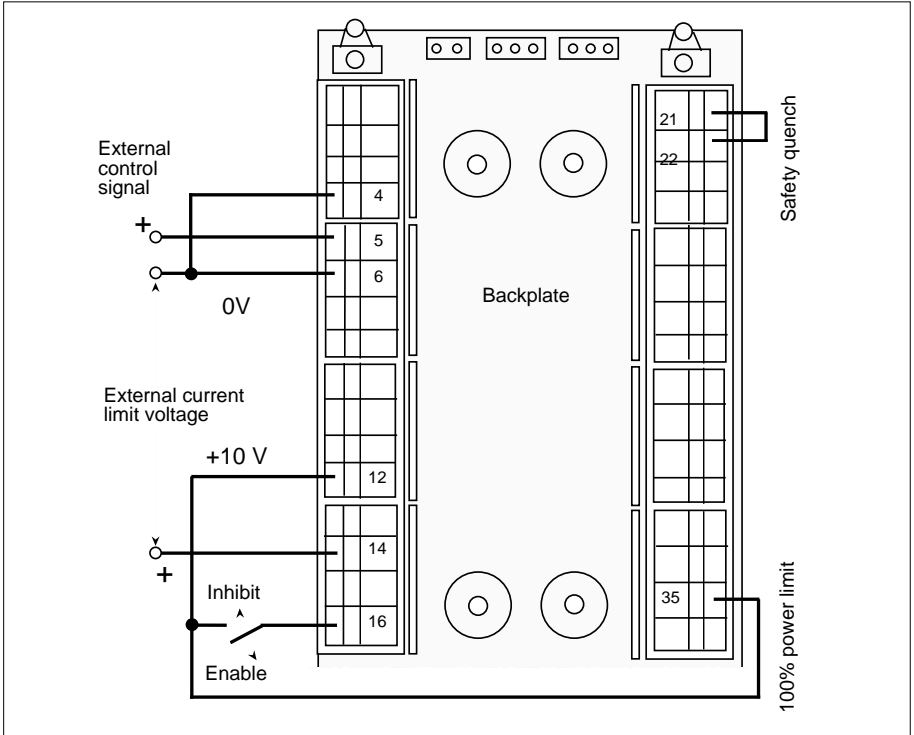

Figure 3-12 External voltage connection for the threshold current limit

When an external voltage is used to set the limit threshold, it reacts **in cascade** with the position of the **I limit / Limit. I** potentiometer on the front panel.

This means that if the **I limit / Limit. I** potentiometer is set, for example, to 50% current, the external voltage from **0 V** to **10 V** limits the maximum current from 0% to 50% of the nominal thyristor unit current.

The 'Current limit' (terminal **14**) input impedance is greater than or equal to **150 kΩ**.

Limit set using an external potentiometer

For the threshold current limit, it is possible to use an external potentiometer.

A **10 k Ω** potentiometer should be connected between terminals **6 ('0 V')** and **12 ('+10 V')** of the control terminal block.

The potentiometer wiper should be connected to terminal **14 ('Current limit')**.

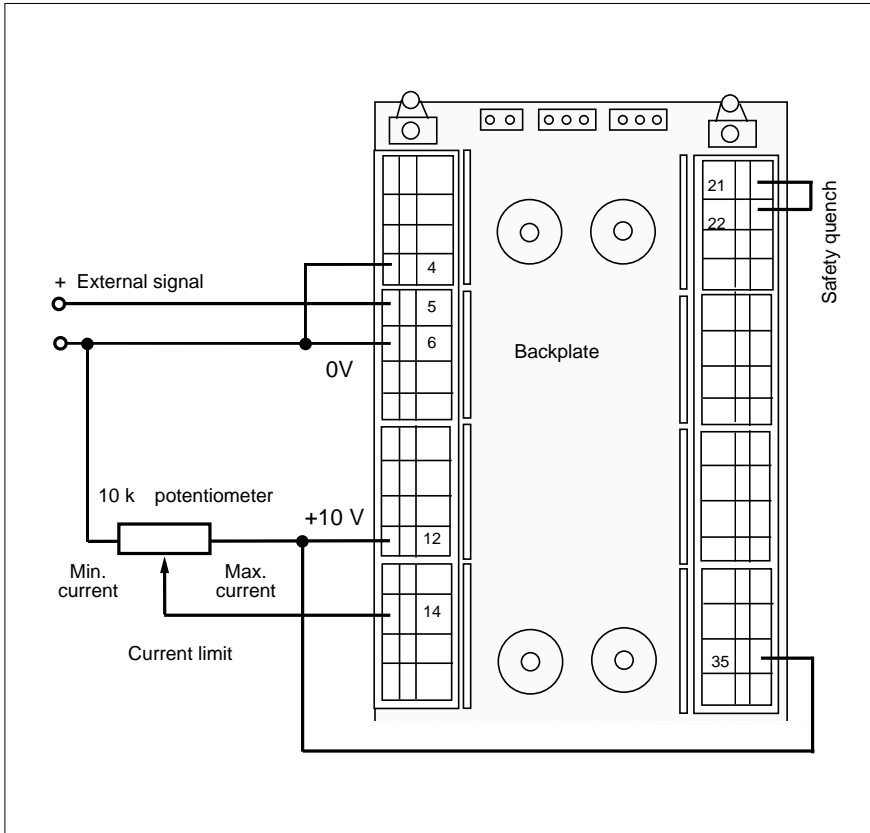

Figure 3-13 External potentiometer connection for the threshold current limit

The external potentiometer reacts **in cascade** with the **I limit / Limit. I** potentiometer on the front panel.

If the **I limit / Limit. I** potentiometer is set, for example, to 70% current, the external potentiometer can limit the maximum current from 0% to 70% of the nominal thyristor unit current.

Power limit connection

The standard version of the **470** series thyristor units is equipped with the threshold limit of the controlled parameter (power, squared current or squared load voltage).

This limit is a function which is used to limit the load current to a specified value, independently from the setpoint.

The controlled parameter limit is called the '**Power limit**' since, at a constant load resistance, the parameters V^2 and I^2 are proportional to a dissipated power.

If the current limit option is used and if the parameter I^2 is selected for control, these two limits (current and power) are redundant.

The power limit threshold can be set in the following ways:

- by the '**P.Limit**' potentiometer on the front panel
- by an external voltage (in cascade with the '**P.Limit**' potentiometer)
- by an external potentiometer (in cascade with the '**P.Limit**' potentiometer).

Power limit set using the potentiometer on the front panel

For the load power threshold limit using the '**P.Limit**' potentiometer, terminal **35** ('Power limit input') on the driver terminal block should be connected to terminal **12** ('+ 10 V') on the control terminal block.

The maximum power limit varies between **0%** (when the '**P.Limit**' potentiometer is turned completely **anti-clockwise**) and **100%** (when the potentiometer on the front panel is turned completely **clockwise**).

Limit set using an external potentiometer

The threshold power limit can be set using an external potentiometer.

A **10 k Ω** external setting potentiometer should be connected between terminals **6 (0 V)** and **12 (+10 V)** on the control terminal block.

The potentiometer wiper should be connected to terminal **35 (Power limit input)** on the driver terminal block.

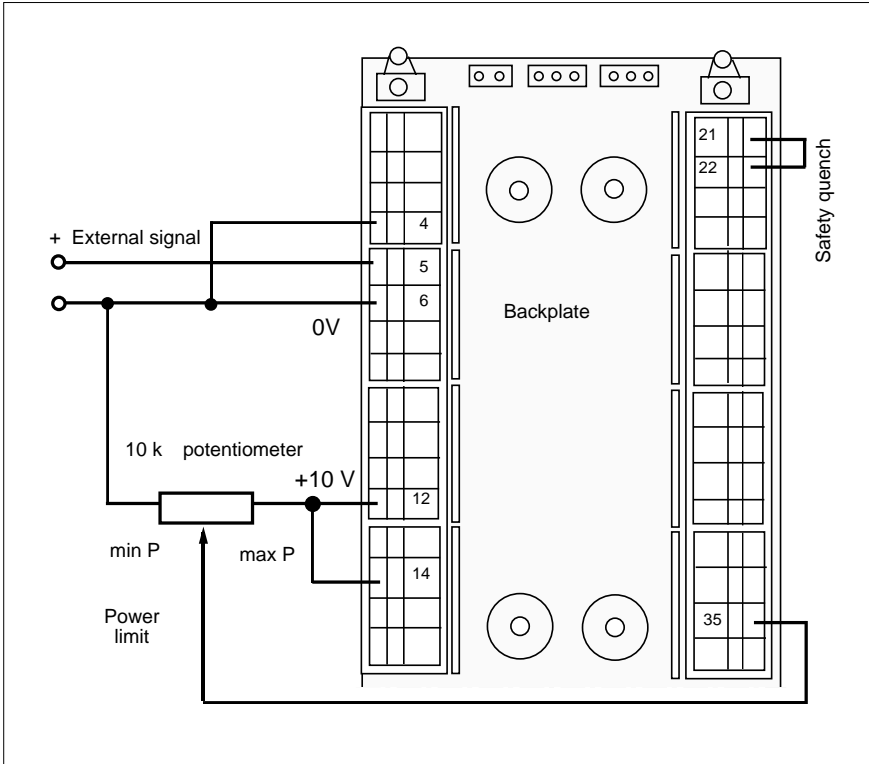

Figure 3-14 External potentiometer connection for the power limit

The power limit threshold setting (using an external potentiometer) reacts **in cascade** with the '**P. Limit**' potentiometer on the front panel.

Setting using an external voltage

The power limit threshold setting external voltage reacts **in cascade** with the '**P. Limit**' potentiometer on the front panel.

This voltage between **0** and **10 V** should be connected between terminals **6 (0 V)** and **35 'Power limit input'**. Terminal **35** is positive.

Retransmission signals

The **current image** is retransmitted in the form of a **full wave rectified** signal (**2.5 V** mean between terminals **3** and **6** for the nominal load current) **and** in the form of an **AC** signal (**2.5 V RMS** between terminals **34** and **6** in full firing).

The load voltage image is available between terminals **33** and **6** in the form of an AC voltage (**2.5 V RMS** in full firing).

The true power image (or squared load voltage or squared load current) in the form of a DC voltage (**10 V** for a nominal calibrated load power) is available at terminal **36**, referenced in relation to **0 V** (terminal **6**).

The true power information is correct for the 'Phase angle' and 'Single cycle' firing modes; it is modulated as a function of the modulation in 'Burst firing'.

The minimum impedance to be connected to the retransmission outputs is **5 kΩ**.

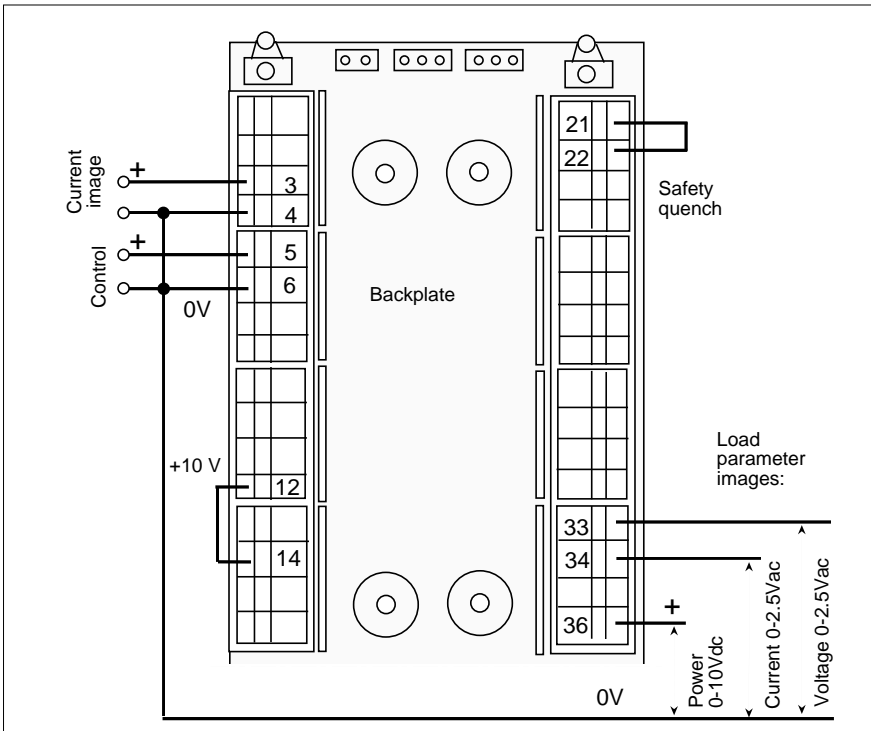

Figure 3-15 Retransmission signal connection

External thyristor block control (472 model)

To control the external thyristor unit, the **driver terminal block** of the electronic driver unit (472 model) is equipped with:

- thyristor firing signal outputs
- a load current measurement signal input.

A load voltage measurement signal input is located on the **user terminal block** (see page 3-5).

The thyristor firing signals are available on terminals **23, 24** and **26, 27**.

Terminals **23** and **24** should be connected to the cathode and gate, respectively, of the external thyristor **T1** (connected in the order 'Line-Load').

Terminals **26** and **27** should be connected to the cathode and gate, respectively, of the external thyristor **T2** (connected in the order 'Load-Line').



Caution !

- Do not invert the 'Cathode-Gate' wires of thyristors T1 and T2
(a PLF alarm is activated since the thyristors cannot output)
 - The **472** driver unit should be at most **80 cm** from the thyristor block.
Twist each pair of 'Cathode-Gate' wires.
 - The twisted wires should not be placed near the power cables.
-

Terminals **38** and **39** are to be used for the secondary coil connection of the external current transformer (nominal current **5 A**) .



Warning !

The current transformer should ensure dual isolation between the primary and secondary coils. This isolation should be calculated with reference to the operating voltage (thyristor block supply voltage).



Caution !

The order of connection of the external current transformer must be observed. Otherwise, the output power could be negative and induce a control malfunction.

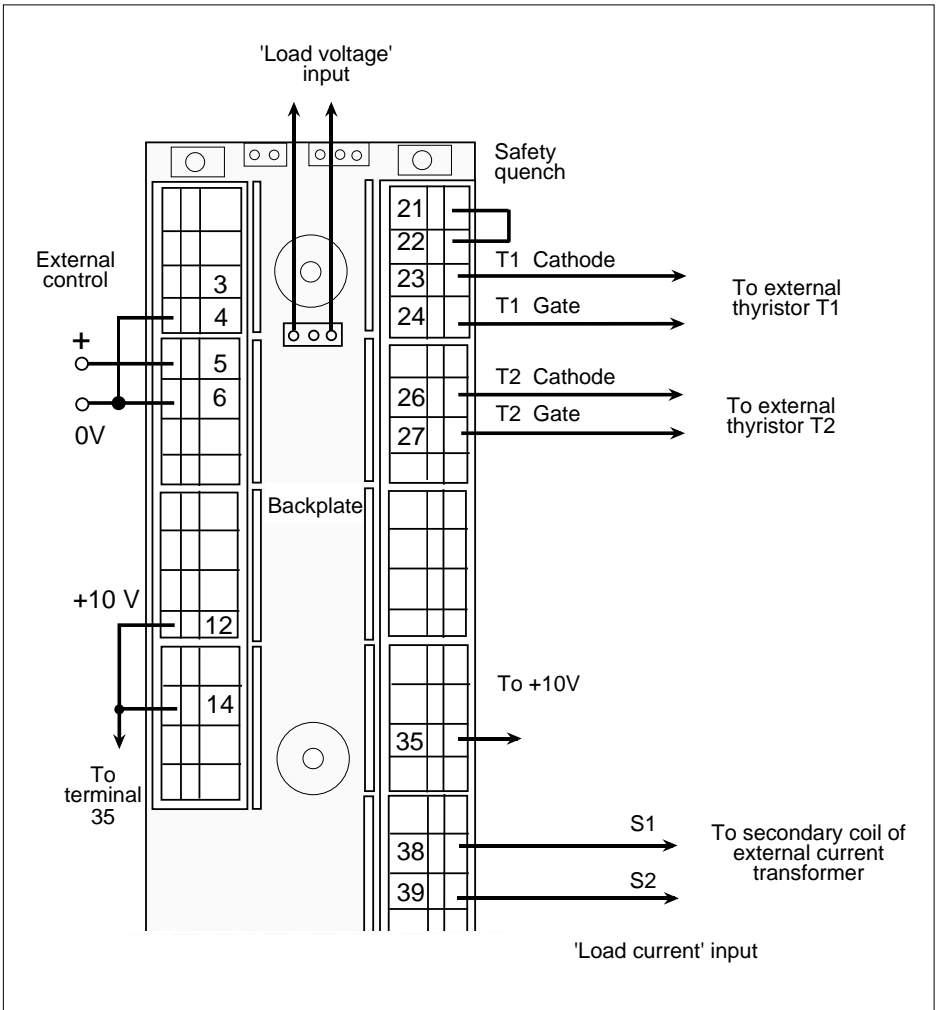

Figure 3-16 External thyristor block control connection (472 model)

For the full wiring diagram of the 472 driver unit, for power, the external thyristor block and the external current transformer, see page 3-28.

EXAMPLES OF WIRING DIAGRAMS

The figures below give examples of full wiring diagrams for power, the auxiliary supply and external control for the two 470 series model types:

- the **470** and **471** models with internal thyristors and incorporated measurement circuits
- the **472** model with an external thyristor block and external current transformer.

The connection details for the power limit, current limit and different types of control are explained in the previous paragraphs.

For the specific features of the auxiliary power supply connection according to the power supply voltage used, see page 3-6.

470 and 471 model thyristor units

The load current passes through the power terminals '**L**' (Line) and '**⌋**' (Load).

The other end of the load is connected either to the neutral or to the second phase of the power supply, depending on the selected configuration. The terminal '**L**' should be connected to the **phase** of the power supply (see figure 3-17).

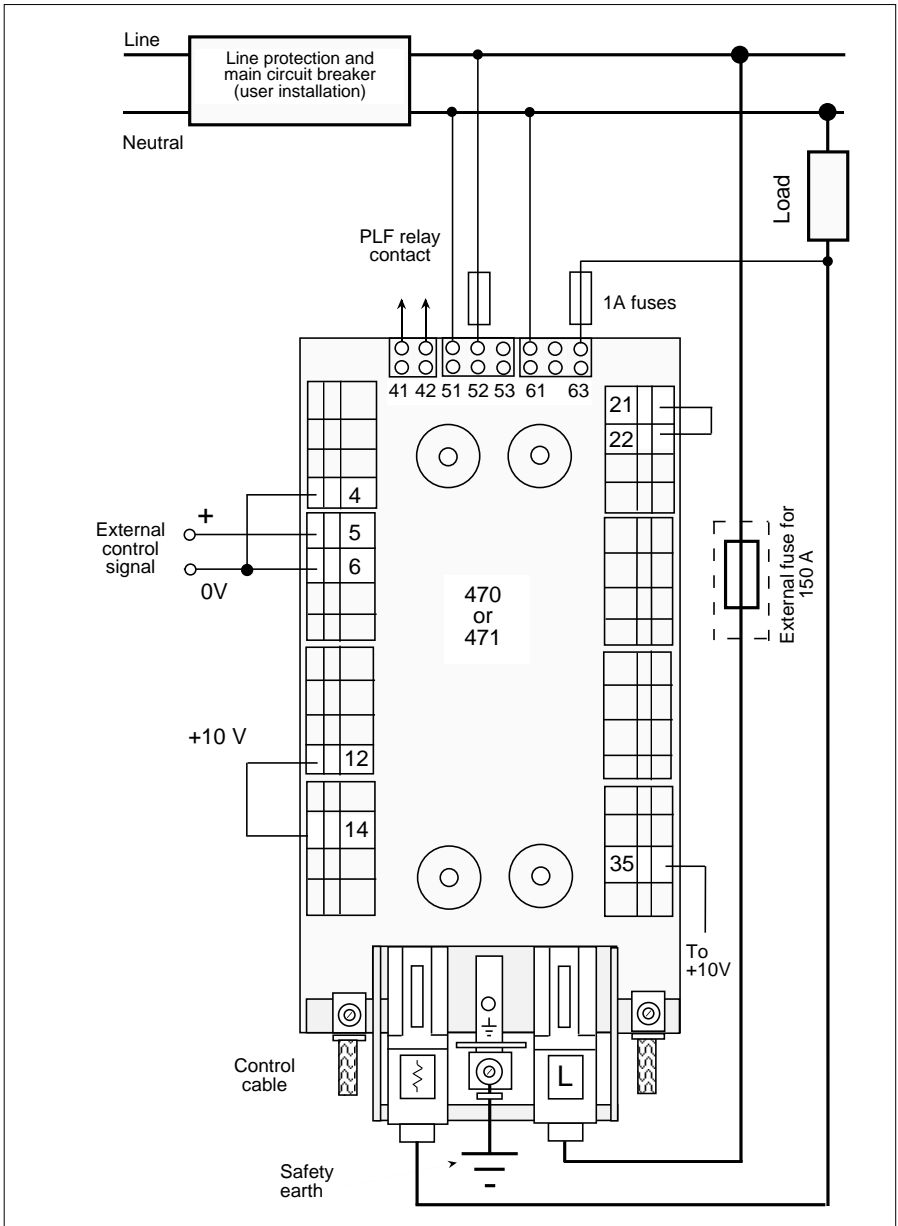

Figure 3-17 Example of 470 and 471 thyristor unit connection (Line-Neutral wiring)

Driver unit, 472 model

The power section and the 472 driver unit are connected with thyristor firing signal connections and the load current and voltage measurement circuits.

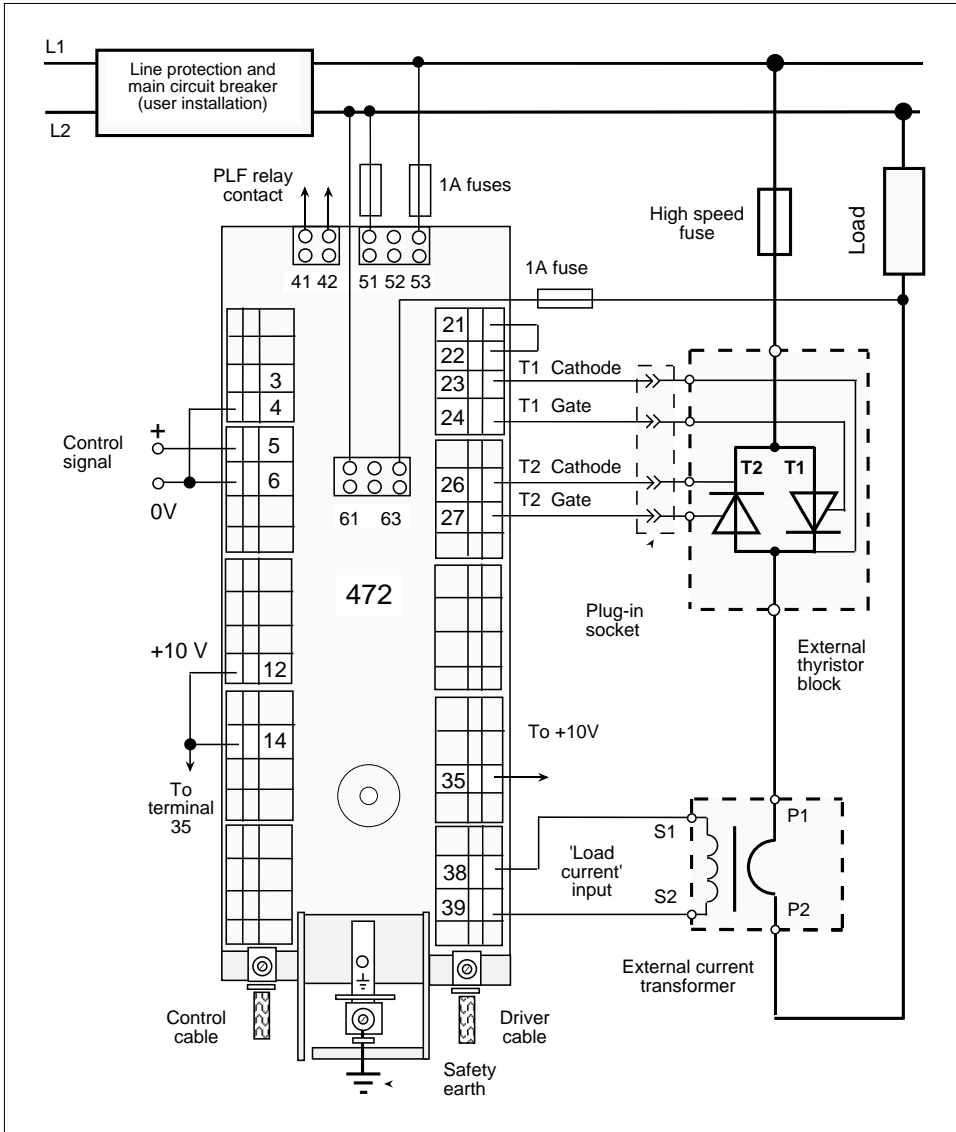

Figure 3-18 Example of 472 driver unit connection (line-to-line wiring)

Chapter 4

CONFIGURATION

Contents	page
Safety during configuration	4-2
Location of the configuration equipment	4-3
Configuration of the control board	4-6
Input type	4-6
Automatic input (external signal)	4-6
Manual input	4-6
Thyristor firing mode	4-7
Frequency	4-7
Configuration of the driver board	4-8

Chapter 4 CONFIGURATION

SAFETY DURING CONFIGURATION

The thyristor unit is configured using mini-switches and mobile **jumpers** located on the control board.

Important !



The unit is supplied fully configured in accordance with the code on the identification label.

This chapter is included in order to

- **check** that the configuration is compatible with the application, or
- **modify**, if necessary, certain characteristics of the thyristor unit on-site.

Warning !



For safety reasons, the reconfiguration of the thyristor unit using jumpers must be performed with the unit **switched off** by qualified personnel.

Before starting the reconfiguration procedure, check that the thyristor unit is isolated and that an occasional power-up is impossible.

After the reconfiguration of the unit, correct the codes on the identification label to prevent any maintenance problems later.

LOCATION OF THE CONFIGURATION EQUIPMENT

The jumpers and configuration mini-switch strips are located on the thyristor unit control and driver boards.

The configuration mini-switches can be accessed at the rear of the unit when it is unplugged from its backplate. Their positions can be changed using a **0.4 x 2.5 mm** flat screwdriver.

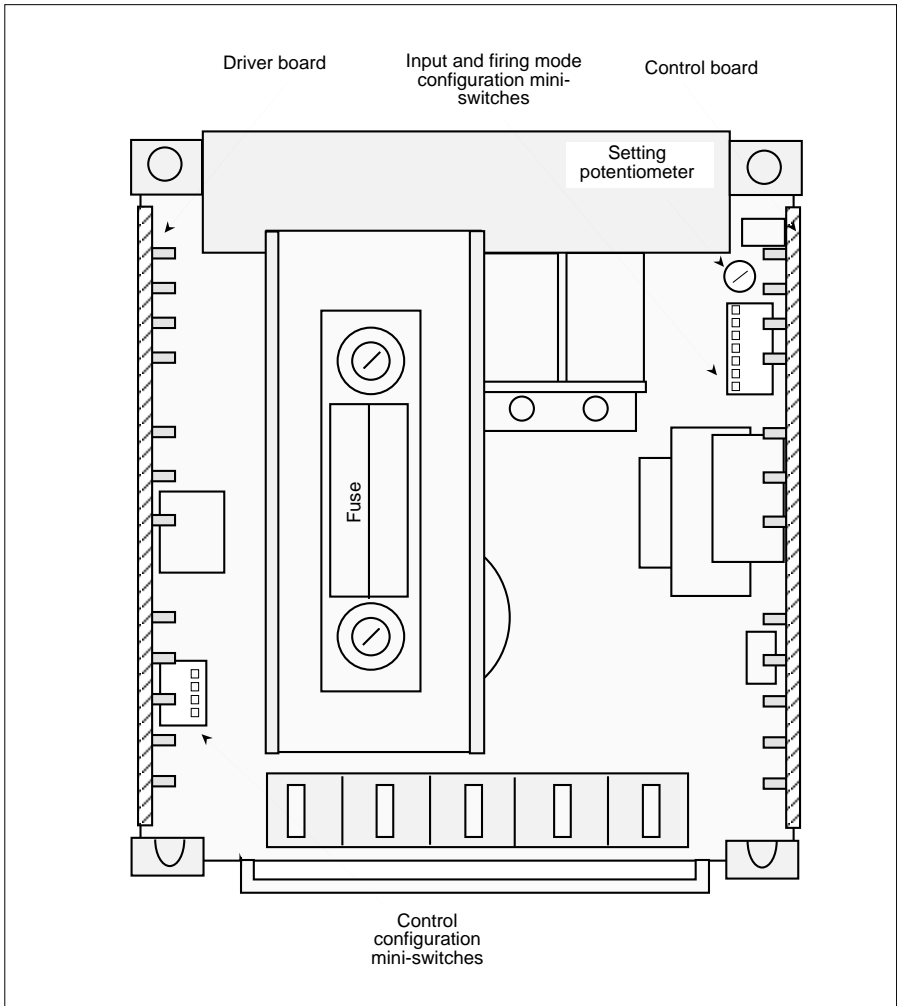

Figure 4-1 Rear view of the 470 series thyristor unit (without backplate)

Two strips of mini-switches are used to configure:

- the input type and the control signal level
- the thyristor firing mode
- the frequency of the power supply used
- the controlled parameter (feedback)

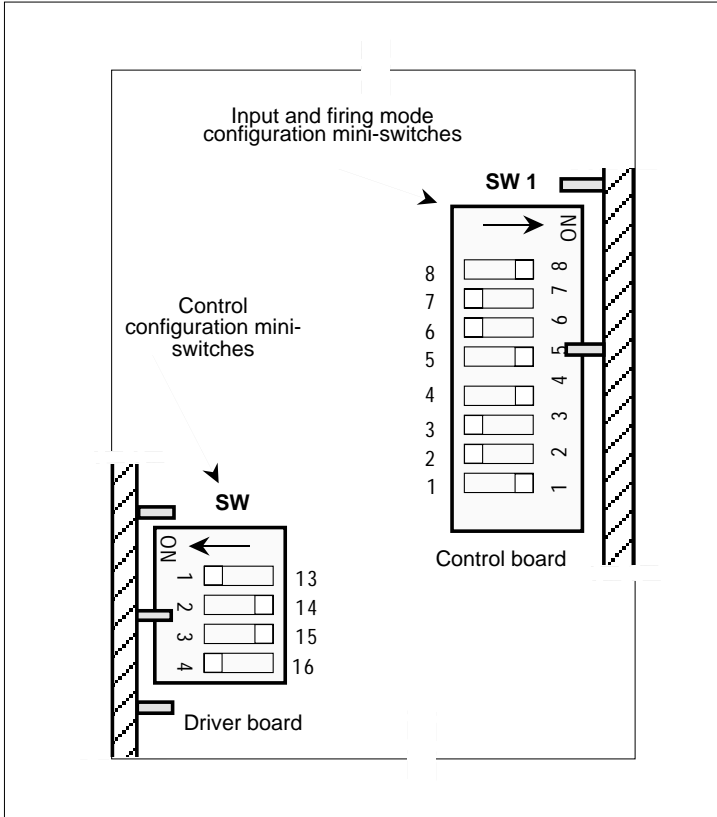

Figure 4-2 Mini-switch strips

In the configuration tables below, the switches of the mini-switches are indicated as follows:

- 1** - switch **lowered** towards the board (**ON** position)
- 0** - switch **raised**.

Two configuration jumpers **J1** and **J2** are located on the control board.

They are used to configure:

- soft start / end
- the Burst firing mode (fast cycle or slow cycle)

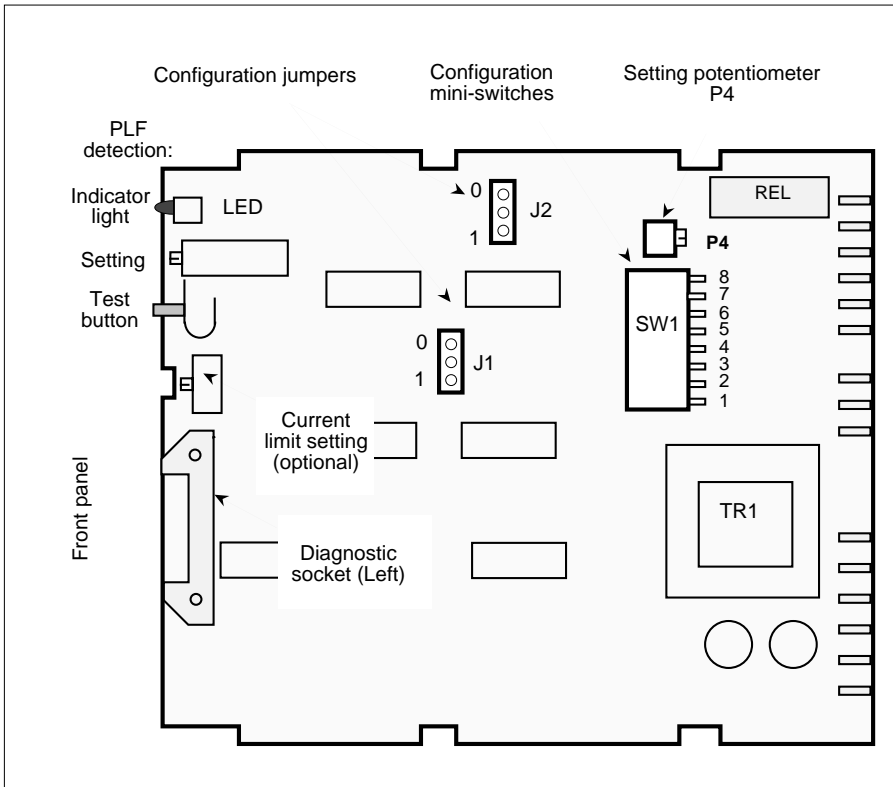

Figure 4-3 Location of configuration equipment on the control board.

Thyristor units ordered with a short code are supplied with the following configuration:

- the input configured for 4-20 mA
- the thyristor firing mode: firing angle variation (Phase angle)
- frequency 50 Hz
- the thyristor delayed firing potentiometer set to the maximum start ramp (resistive load) and to 90° delayed firing (inductive and transformer connected load).

CONFIGURATION OF THE CONTROL BOARD

Input type

The input signal type is configured using mini-switches **1** to **4** (strip **SW1**).
 Reconfiguration is possible when the thyristor unit is disconnected from its backplate.

In tables 4-1 to 4-4, the **1** indicates the lowered position of the switch (towards the board).

Automatic input (external signal)

Automatic external input signal	Position of the mini-switches SW1			
	1	2	3	4
0-5 V	0	0	0	0
0-10 V	1	0	0	0
1-5 V	0	1	0	0
0-5 mA	0	0	1	0
0-10 mA	1	0	1	0
1-5 mA	0	1	1	0
0-20 mA	0	0	1	1
4-20 mA	0	1	1	1

Table 4-1 Configuration of the automatic input

Manual input

The manual input voltage range (external potentiometer wiper at terminal **4**) depends on the configuration of the automatic input. Table 4-2 gives the manual input voltage range as a function of the limit positions of the potentiometer.

Position of mini-switches		Voltage range at manual input
1	2	
0	0	0-5 V
1	0	0-10 V
0	1	1.25 V - 6.25 V

Table 4-2 Configuration of the manual input

In position **8L** of the diagnostic unit (left socket), 100 % control corresponds to **-5 V**.

Thyristor firing mode

The thyristor firing modes can be configured using **mini-switches 5 to 7** (strip **SW1**) and by two **jumpers J1** and **J2** located on the control board.

Thyristor firing mode	Position				
	SW1 mini-switches			Jumpers	
	5	6	7	J1	J2
Firing angle variation	0	0	0	0	-
Single cycle	1	0	0	0	-
Fast cycle	1	1	0	0	-
Slow cycle	1	1	0	1	-
Fast cycle with soft start	1	1	1	0	1
Slow cycle with soft start	1	1	1	1	1
Fast cycle with soft start and end	1	1	1	0	0
Slow cycle with soft start and end	1	1	1	1	0

Table 4-3 Configuration of the firing mode

- Note:**
- If the jumper **J1** is in position **1** in Phase angle, the response time on setpoint variation is multiplied by **10**.
 - '-' in table 4-3 indicates that the jumper position is irrelevant.

Frequency

The frequency used is configured using mini-switch **8** (strip **SW1**).

Frequency	Position of mini-switch 8
50 Hz	1
60 Hz	0

Table 4-4 Configuration of the power supply frequency used

CONFIGURATION OF THE DRIVER BOARD

The driver board comprises the strip **SW** of mini-switches used to configure the parameter controlled by the control system (feedback).

Reconfiguration is possible when the thyristor unit is disconnected from its backplate (see figure 4-1).

Controlled parameter	Position of SW mini-switches			
	13	14	15	16
True power	1	0	0	1
Squared RMS load voltage	0	1	0	1
Squared RMS load current	1	0	1	0

Table 4-5 Configuration of the controlled parameter

In the above table, the **1** indicates the position of the mini-switch lowered towards the board (position marked **ON**; see figure 4-2).

Chapter 5 OPERATION

THYRISTOR FIRING MODES

General

The 470 series thyristor units have the following thyristor firing modes:

- Phase angle
- Burst firing ('fast', 'slow' or 'single cycle') with or without soft start (start and end).

They can be reconfigured by the user as described in the 'Configuration' chapter.

'Phase angle' mode

In 'Phase angle' mode, the power transmitted to the load is controlled by firing the thyristors for a part of the power supply voltage half-cycle (see figure 5-1).

The **firing angle** (Θ) varies in the same direction as the input signal with the control system.

The power emitted is not a linear function of the firing angle.

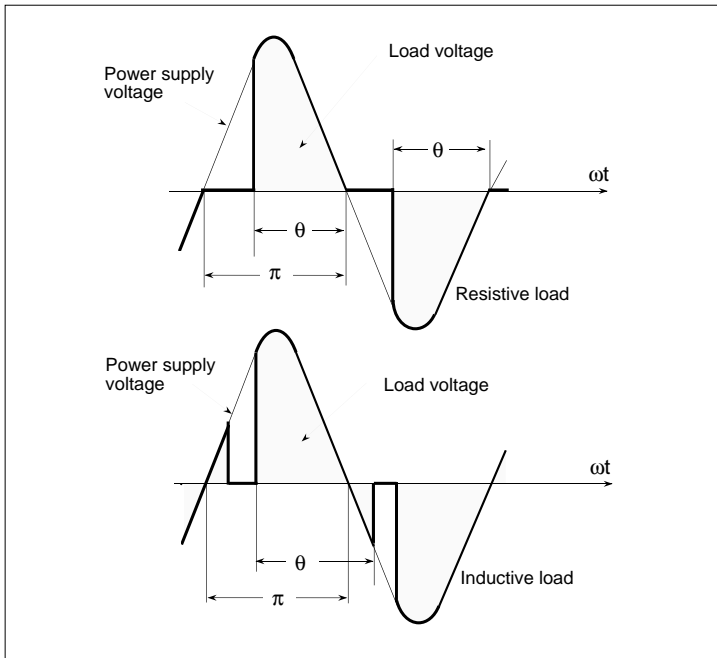

Figure 5-1 'Phase angle' firing mode

'Burst firing' mode

The '**Burst firing**' mode is a **proportional cycle** which consists of supplying a series of **complete** power supply voltage **cycles** to the load.

Thyristor firing and non-firing are synchronised with the power supply and are performed **at zero voltage** for a resistive load.

This firing eliminates the steep fronts of the power supply voltage applied to the load, **does not produce interference** on the supply and, in particular, prevents the generation of parasites.

In the '**Burst firing**' thyristor firing mode, the power supplied to the load depends on firing times T_F and non-firing times T_{NF} . The load power is proportional to the firing rate τ and is defined by the ratio of the thyristor firing time (T_F) and the modulation time ($T_M = T_F + T_{NF}$).

The firing rate (or cyclic ratio) is expressed by the following ratio:

$$\tau = \frac{T_F}{T_F + T_{NF}}$$

The load power can be expressed by:

$$P = \tau \cdot P_{MAX}$$

where P_{MAX} represents the load power during thyristor firing.

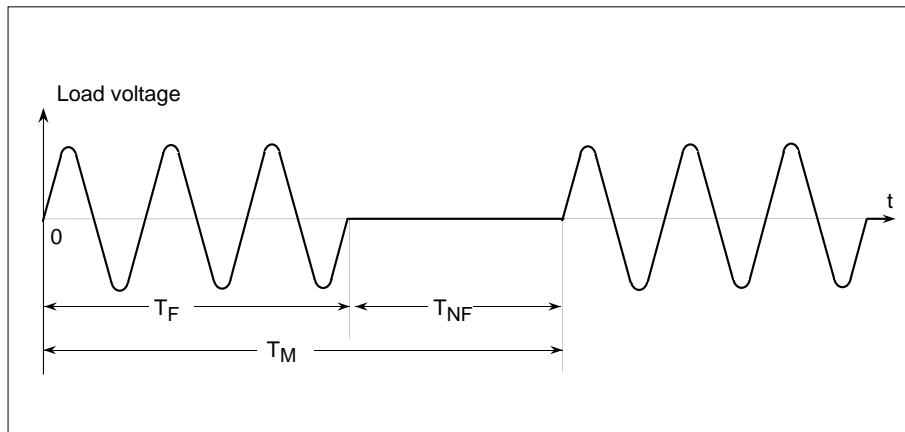

Figure 5-2 Firing times of a burst firing cycle

'Single cycle' mode

The '**Burst firing**' mode with a **single** firing or non-firing time is called the '**Single cycle**' mode.

Modulation time

The modulation time in 'Burst firing' mode is **variable** according to the output power. Due to this type of control, the 470 unit possesses setting precision adapted to each specific setpoint zone:

- At **50 %** power, the typical value of the modulation time is:
 - **0.8 s** for the 'Fast' cycle
 - **8 s** for the 'Slow' cycle.
- For a zone below **50 %** of the maximum setpoint, the **firing** time decreases and the modulation time increases.
- For a power zone above **50 %**, the **non-firing** time decreases as the modulation time increases.

For example, in the 'Fast' cycle mode:

- for 5 % power, $T_F = 250 \text{ ms}$, $T_M = 5 \text{ s}$
- for 90 % power, $T_F = 2.25 \text{ s}$, $T_M = 2.5 \text{ s}$.

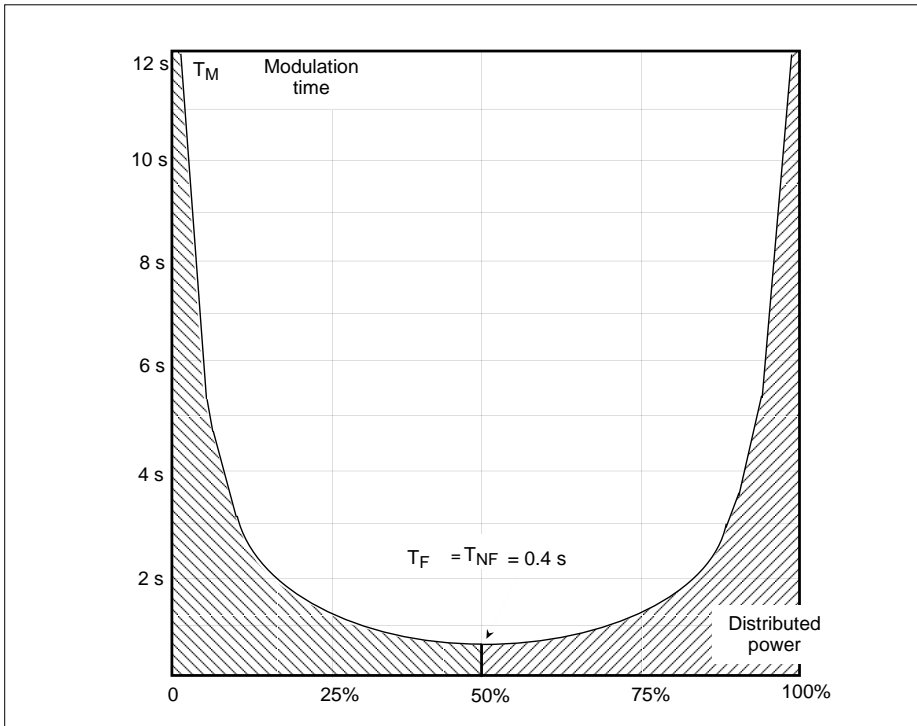

Figure 5-3 Modulation time as a function of power ('Fast' cycle)

Soft start / end

Soft operation (start or start and end) can be configured in the 'Slow cycle' and 'Fast cycle' Burst firing modes.

The soft start duration (T_{ss}) is the time taken for the thyristor unit output power to change from **0%** to **100%** by varying the thyristor firing angle from **0** to **full firing**.

The soft end duration (T_{se}) is the time taken for the thyristor unit output power to **change** from **100%** to **0%** by varying the thyristor firing angle from **full firing** to **0**.

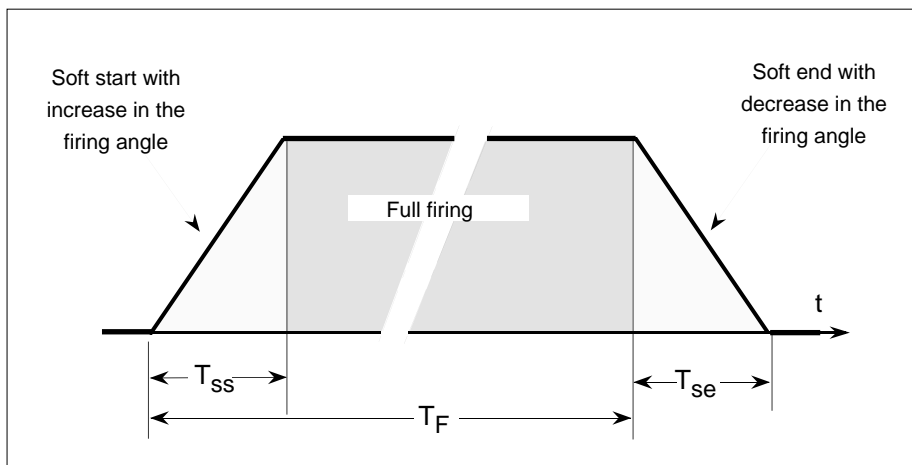

Figure 5-4 Soft start and end in burst firing mode

The duration of the soft start (and end) can be set from **0** to **250 ms** by the potentiometer on the control board (See 'Commissioning' chapter).

The soft end time (T_{se}) is not included in the firing time (T_F), but all the power sent to the load is taken into account in the control.

After the soft start with thyristor firing angle variation, the thyristor unit remains in **full firing** during the firing time (if the current limit is not enabled).

Note : For soft starts of loads with very high resistance variations as a function of temperature (e.g.: Kanthal Super), use the **Special 677**.

Over-current elimination for the inductive load

The 'Fast cycle' and 'Slow cycle' Burst firing modes, composed of complete supply cycles, start at zero voltage for purely resistive loads.

For non-saturating inductive and transformer connected loads, in Single cycle and Burst mode without soft start, firing at zero voltage generates transient operation which could, in certain cases, induce the appearance of over-currents (figure 5-5,a) and a blow-out of the thyristor protection fuse.

To prevent this over-current, the first firing of the thyristors for **non-saturating** inductive and transformer connected loads can be **delayed** with reference to the corresponding zero voltage (figure 5-5,b). The optimum **delay angle** (ϕ) must be adjusted with the potentiometer on the control board (see adjustment) as a function of the load (max. delay 90°).

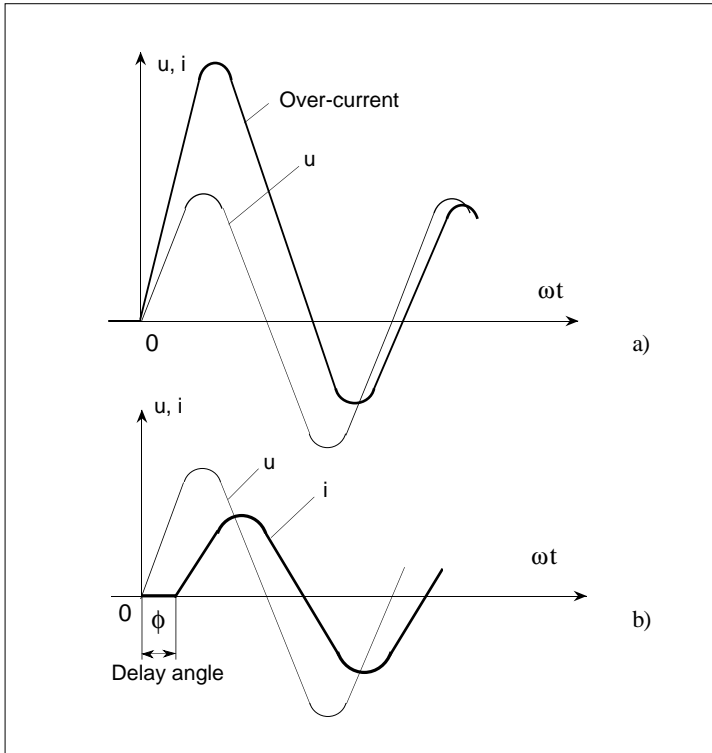

Figure 5-5 Inductive load switching at zero voltage (a) and with delay angle (b)

This firing mode is not suitable for saturating loads (transformer primaries) since **470** series units do not generate magnetisation ramps at power-up.

CONTROL

Control function

Using the current and voltage **measurement**, the following feedbacks are available:

- the true power of all load types (this power takes into account the possible phase shift between the instant current and voltage),
- the squared RMS current,
- the squared RMS voltage.

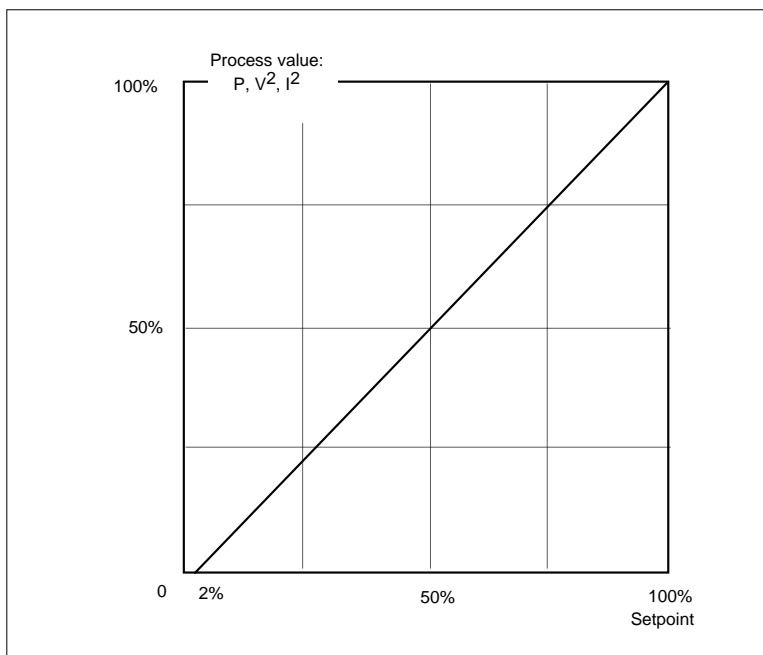

Figure 5-6 Controlled parameter as a function of the setpoint

The controlled parameter (power, squared current or squared voltage) at the thyristor unit output is linear between **0** and **100 %** of its maximum value as the input signal varies between **2** and **100 %** of the maximum scale.

The accuracy of the control is guaranteed to be within $\pm 2 \%$ of the maximum value.

The use of the **true power** in a control loop enables:

- the supply of an accurate power of the load independent of variations in the power supply voltage or the load resistance (due to the temperature change or ageing of the components),
- thermal control when the temperature of the heated component cannot be measured.

Power control is required for certain processes in which the temperature cannot be controlled, for instance, when the user requires power information (process monitoring or calculation of the cost of energy for heat treatment).

Important !

For loads with high resistance variations as a function of temperature (molybdenum, molybdenum bisilicide, tungsten, platinum, etc), at low temperatures, the 470 series units can switch to current limit (if this option is installed) and therefore no longer operate in power control mode.

The **squared RMS load voltage** or the **squared RMS current** represents the dissipated power in a purely resistive and constant load.

For loads with low resistance variations as a function of temperature (iron alloys, nickel, chromium, aluminium, Inconel, etc.), control in **V²** is sufficient.

Pulse gating

The **470** series thyristor unit thyristors are fired by a gate **pulse train** of a maximum duration of **5 ms**

In most single-phase applications, it is possible to send gate pulses every **10 ms** so that the thyristors are polarised in direct mode (positive anode in relation to the cathode) or in inverse mode (negative anode).

Each thyristor is only fired when its voltage is positive, when it is negative, the anti-parallel thyristor is fired.

In certain applications, the gate pulses on the polarised thyristor in inverse mode can lead to operating problems: firing instability, fuse blow-out.

It is therefore necessary to **eliminate** the gate pulses when the thyristor is polarised in **inverse** mode.

This function is performed by the **pulse gating** circuit available for **470** thyristor units.

This pulse gating is essential for configurations in which multiple thyristor units are distributed between the phases of a three-phase power supply and have an electrical configuration which could induce a **phase shift** between the voltage applied to the thyristor and the electronic supply voltage.

For example:

- control of heating electrodes (in transformer secondary coil) immersed in the same molten glass bath
- load in star with neutral, with the central point of the star connected to the power supply neutral by a wire of a non-negligible resistance with reference to that of the load.

POWER LIMIT

Using the load current and voltage measurement, the **470** series thyristor units can use a threshold limit of the controlled parameter (true power, squared RMS load current or RMS load voltage).

The 'Power limit' function **limits** the controlled parameter to a **specified value** independently from the input signal.

The maximum threshold of the dissipated power in the load (or the threshold of the parameters V^2 and I^2 proportional to a power for the constant resistance) is set using the '**P.Limit**' potentiometer on the front panel of the thyristor unit.

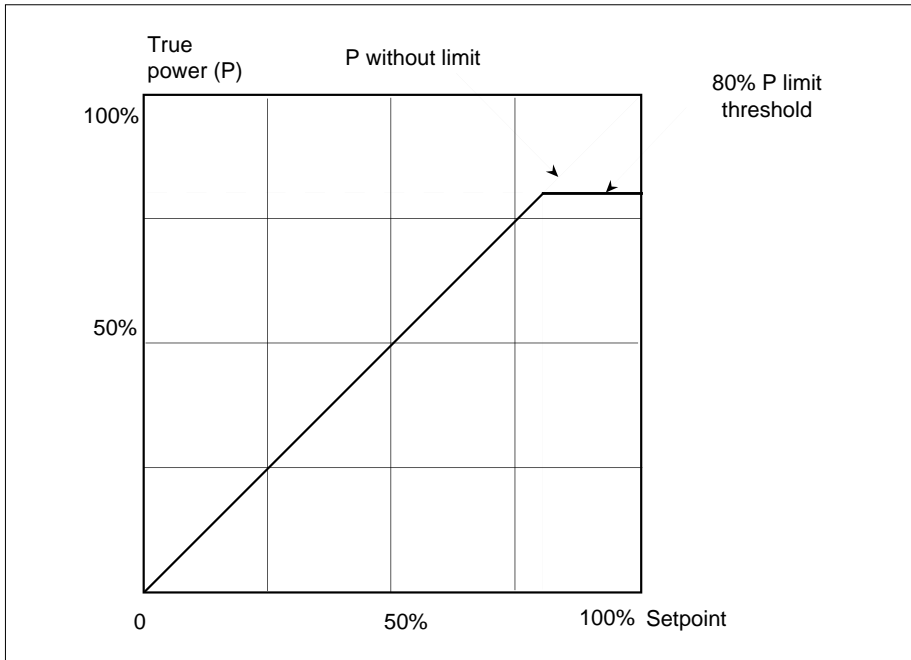

Figure 5-7 Threshold power limit

A **remote** power limit is possible using **external** components (external potentiometer or voltage, see 'Wiring' chapter).

In this case, the limit is **in cascade** with the setting using the front panel potentiometer.

The '**P.Limit**' potentiometer is used to set the maximum threshold of the power and the external components (potentiometer or voltage) adjust the power value between **0 %** and the **valeur set** using the '**P.Limit**' potentiometer on the front panel.

CURRENT LIMIT (OPTIONAL)

As an option, the **470** series thyristor units can use the current measurement to limit the RMS load current to a **specified value** independently from the external input signal applied to terminal 5 or 6.

This function gives a limit of the squared RMS load current I^2 .

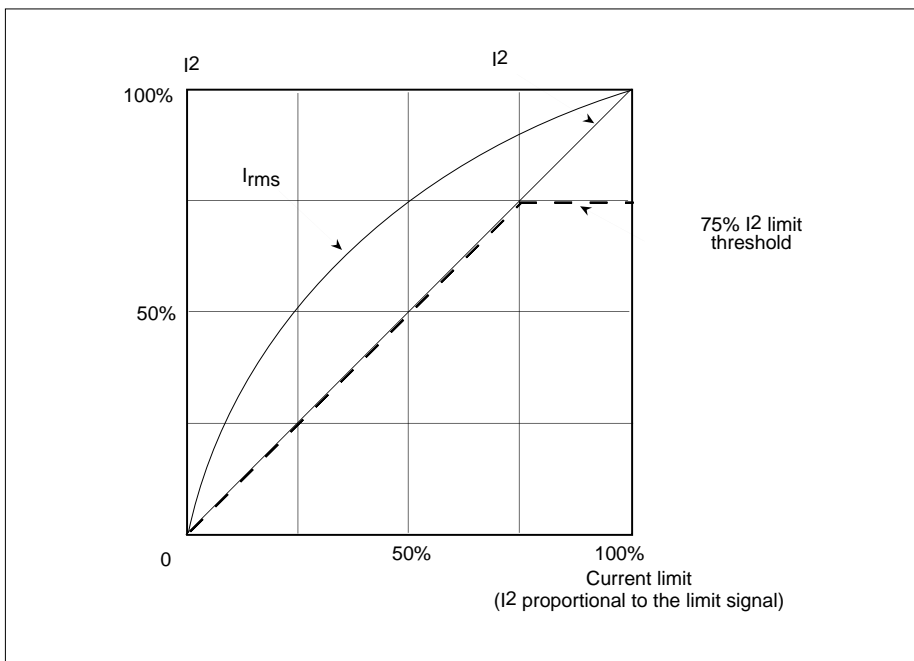

Figure 5-8 Example of current limit (low temperature coefficient load)

For the current limit, the maximum load current threshold is set using the potentiometer marked '**I limit / Limit. I**' on the front panel.

The 'Threshold limit' input can also be controlled:

- by an external setting **potentiometer**
- by a **0-10 V** external DC voltage.

which act in cascade with the '**I limit / Limit. I**' potentiometer on the front panel.

The limit threshold can be adjusted for the RMS load current from **0 %** to **110 %** of the **nominal current** (from 0 % to 120 % of the squared current)

PARTIAL LOAD FAILURE DETECTION

The 'partial load failure' (**PLF**) alarm detects an increase in the load impedance due to the failure of heating elements, for example.

The sensitivity of the PLF circuit is used to detect the increase in the load impedance to **20 %**, which detects the failure of one element out of **5** identical elements mounted in parallel.

On the **470** thyristor unit, the alarm is indicated:

- by an **indicator light** mounted on the front panel and labelled '**Load Fail**' (lit when a partial load failure is detected)
- by an alarm relay **contact** (contact output is available on terminals **41** and **42** on the user terminal block at the top left-hand corner of the thyristor unit backplate; see page 3-5).

The alarm relay is **de-energised** in the alarm state when the thyristor unit power is on.

The alarm contact (cutoff capacity **0.25 A** at **250 Vac** or **30 Vdc**) in the standard version is **open in the alarm state** or in the event of a unit **supply failure**.

The contact cutoff capacity must not exceed **250 V** in any circumstances.

As an option (code **83**), this contact is **closed** in the alarm state.

The PLF alarm relay is acknowledged either by switching off the thyristor unit or by a return to the nominal current.

RETRANSMISSION

The **470** thyristor units possess retransmission of load current, voltage and power images in the form of a DC and AC signal.

Load current image

A **DC** load current retransmission signal is available on the control terminal block, between terminals **3** ('**Current image**') and **6** ('**0V**'). The full wave rectified output signal is proportional to the **instant** load current (**2.5 V** mean for the nominal current of the thyristor unit).

An **AC** signal, proportional to the RMS load current, is available at terminal **34** of the driver terminal block. It is referenced in relation to **0 V** (terminal **6**) and equal to **2.5 V** RMS for the nominal current of the thyristor unit (after calibration).

The current image can be used for tests or for an external measurement (minimum impedance of circuit connected in parallel: **20 kΩ** for the DC signal and **5 kΩ** for the AC signal).

Load voltage image

The **AC** load voltage retransmission signal is available between terminals **33** ('**Load voltage image**', driver board) and **6** ('**0V**', control board).

This signal is proportional to the RMS load voltage and equal to **2.5 V** RMS for the nominal load voltage.

Minimum impedance of circuit connected in parallel: **5 kΩ**

True power image

The **0-10 V** DC true power retransmission signal is available at terminal **36** of the driver terminal block. It is referenced in relation to **0 V**.

The power indication is **10 Vdc** for a **nominal** power transmitted to the load (nominal power equal to the product of the nominal load voltage by the nominal load current after **calibration**).

Minimum impedance of circuit connected in parallel: **5 kΩ**

The true power image is **DC** for the 'Phase angle' and 'Single cycle' firing modes. It is **modulated** in 'Burst firing' as a function of the thyristor firing modulation.

INHIBIT AND SAFETY QUENCH

The **470** thyristor units possess an **active operation inhibit** which requires a voltage to be applied to a control terminal block.

The absence of the inhibit voltage enables the operation of the thyristor unit.

The inhibit input is available between terminal **16** (**Enable input**) and terminal **6** (**0 V**) of the control board.

The inhibit is active when a DC voltage of **+10 V** (**4 V** minimum, **32 V** maximum) relative to terminal **6** (**0 V**) is applied to terminal **16** (see 'Wiring' chapter).

To inhibit the thyristor unit the **'Enable input'** terminal can be connected (using a normally closed contact) to the **'+10 V'** voltage output (terminal **12**) on the control terminal block.

If the thyristor unit is inhibited, the thyristor firing signals are eliminated irrespective of the input signal.

To enable the thyristor unit, terminal **16** must not be connected to a voltage specified above.

The thyristor unit can be inhibited by disconnecting the **safety quench** connection (terminals **21** and **22** of the driver terminal block).

This connection is made using a link on the driver terminal block.

Terminals **21** and **22** can be used for the serial connection of any safety contact (e.g. thermal safety switch). In this case, the external connection wires should be shielded, with the shielding earthed at both ends.

Chapter 6

COMMISSIONING PROCEDURE

Contents	Page
Commissioning procedure safety	6-2
Checking the characteristics	6-3
Load current	6-3
Power supply voltage	6-3
Auxiliary supply voltage	6-3
Input signals	6-3
Partial load failure detection	6-3
External thyristor blocks	6-3
Diagnostic unit	6-4
Calibration	6-9
Preliminary settings	6-10
Default position of potentiometer P4	6-11
Resistive load with low resistance variations	6-11
Resistive load with high resistance variations	6-11
Non-saturating inductive load	6-12
Saturating inductive load	6-12
Partial load failure detection setting	6-14
Current limit setting (optional)	6-15
Power limit	6-16
Checks in the event of abnormal operation	6-17

Chapter 6 COMMISSIONING PROCEDURE

Read this chapter carefully before commissioning the thyristor unit

COMMISSIONING PROCEDURE SAFETY



Important !

Eurotherm cannot be held responsible for any damage to persons or property or for any financial loss or costs resulting from the incorrect use of the product or the failure to observe the instructions contained in this manual.

It is therefore the user's responsibility to ensure that all the nominal values of the power unit are compatible with the conditions of use and installation before commissioning the unit.

Warning !



- **Never use** a thyristor unit with a power supply **voltage greater** than the nominal voltage of the thyristor unit as specified in the coding.
- Dangerous live parts can be accessible when the unit is dismantled from its backplate
- Access to internal components of the thyristor unit is prohibited to users who are not authorised to work in industrial low voltage electrical environments.
- The temperature of the heatsink can be greater than 100°C. Avoid any contact with the heatsink, even momentarily, when the thyristor unit is operating.

The heatsink remains hot for approximately 15 min after the unit has been switched off.

CHECKING THE CHARACTERISTICS

Caution !



Before switching on the unit, make sure that the **identification code** of the thyristor unit corresponds to the coding specified in the **order** and that the characteristics of the thyristor unit are **compatible with the installation**.

Load current

The maximum load current must be less than or equal to the value of the nominal current of the thyristor unit taking the load (component tolerance) and power supply (+10%) variations into account.

Power supply voltage

The nominal value of the thyristor unit voltage must be greater than or equal to the voltage of the power supply used.



Caution !

Given the inhibit at 70 % of the nominal voltage, the nominal voltage of the thyristor unit must be as close as possible to the nominal power supply voltage.

Auxiliary supply voltage

The auxiliary supply voltage must be **in phase** with the power voltage. It is adapted by the position of the soldered links and the choice of the transformers. This selection is made in the factory, depending on the auxiliary supply voltage code.

Input signals

The configuration of the mini-switches on the control board must be compatible with the selected control signal level (see 'Configuration' chapter).

Partial load failure detection

The voltage used for the PLF detection circuit is that used for the auxiliary power supply. This voltage must thus correspond to the power voltage

The PLF alarm relay contact must be connected in the circuit with a voltage which never exceeds 250 V (single-phase or three-phase 230 V power supply).

External thyristor block (472 model)

Check that the connections of the 'Cathode-Gate' twisted wire pairs are correct.

The current of the current transformer secondary circuit must be **5 A** for the nominal current of the primary circuit.

DIAGNOSTIC UNIT

For easier commissioning and setting operations and for the thyristor unit state diagnostics, it is advisable to use the **EUROTHERM type 260** diagnostic unit.

The **20-way switch** of the diagnostic unit is used to display the values of the thyristor unit and controlled parameters on its digital display.

The unit displays two decimal places in order to permit the precise indication of the measured values.

The diagnostic unit possesses a ribbon cable which is plugged into two 20-pin sockets (Left diagnostic socket and Right diagnostic socket) provided on the front panel of the thyristor unit.

Note :

The positions of the diagnostic unit corresponding to the Left socket are marked 'NL' (N - indicates the number of the position); respectively, the positions of the diagnostic unit connected to the Right socket are marked 'NR'.

Tables 6-1 to 6-3 give the description of each position in the diagnostic unit and the typical values of the signals measured for the left and right sockets.



Important !

The values measured are **mean DC values**.

The signals from the diagnostic sockets may also be viewed using an **oscilloscope**.

In order to measure the RMS load voltage and current values (in the diagnostic positions 1R, 2R, 3R, 6R), a **voltmeter** can be connected to the oscilloscope connection terminals.

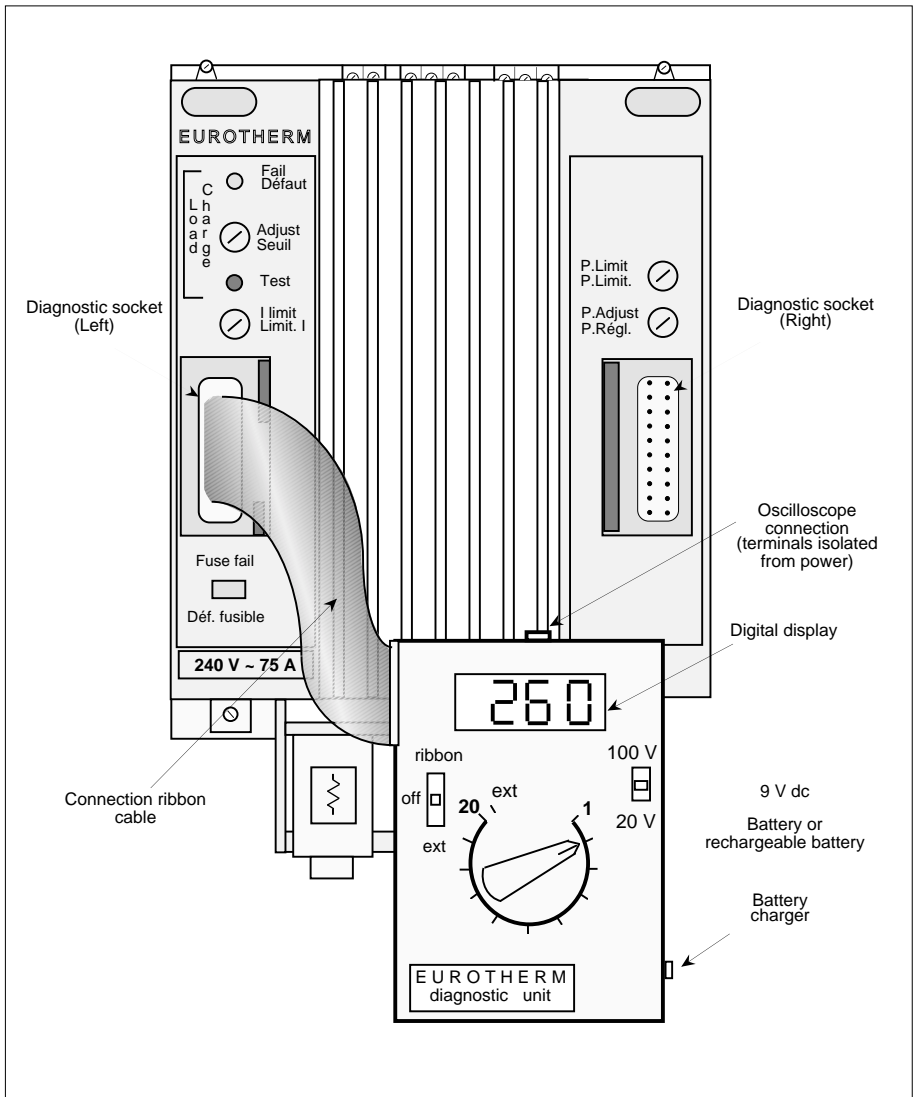

Figure 6-1 Connection of the EUROTHERM type 260 diagnostic unit to a 470 series thyristor unit

Thyristor firing angle variation (Θ)

Position	Assignment	0 % of setpoint $\Theta = 0^\circ$	50 % of setpoint $\Theta = 90^\circ$	100 % of setpoint $\Theta = 180^\circ$
1 L	Current image (full wave rectified)	0 V	1.25 V	2.5 V
2 L	Manual input (if used)	0 V	2.5 V	5 V
3 L	PLF output (not in alarm) In the alarm state	+ 13.5 V - 12.6 V		
4 L	External setpoint Example: 0-10 V	0 V	5 V	10 V
5 L	Threshold current limit (optional)	0 to 10 V		
6 L	Current image for PLF detection	0 V	- 2.5 V	- 4.6 V
7 L	Load voltage image	0 V	2.25 V	4.3 V
8 L	Control setpoint	0 V	- 2.5 V	- 5 V
9 L	Not used			
10 L	Firing demand	0 V _{mean} 1V _{peak}	8.4 V	12.7 V
11 L	'+10V' reference	10 V \pm 0.1 V		
12 L	Auxiliary supply image	- 24 V full wave rectified		
13 L	Pulse output	24V no pulses	24 V pulses	24V pulses
14 L	'-15 V' electronics supply	- 15 V \pm 150mV		
15 L	Oscillator input	0 V	1.2 V 6.4 V _{peak} 90° pulses	1.2 V 6.4 V _{peak} 90° pulses
16 L	'+15 V' electronics supply	+ 15 V \pm 150mV		
17 L	'0' voltage crossing pulse	-10.5 V \pm 12 V _{peak} 0.6ms 100 Hz		
18 L	Electronics supply 0 V	0 V		
19 L	Saw-tooth generator	3.6 V 8.4 V _{peak} 100 Hz		
20 L	Enable	<- 10 V		

Table 6-1 Assignment of the positions of the EURO THERM type 260 diagnostic unit Left diagnostic socket. All models.

Burst mode and single cycle firing

Position	Assignment	0 % of setpoint	50 % of setpoint	100 % of setpoint
1 L	Current image (full wave rectified)	0 V	Modulation 0-2.5 V	2,5 V
2 L	Manual input (if used)	0 V	2.5 V	5 V
3 L	PLF output (not in alarm) In the alarm state		+ 13.5 V - 12.6 V	
4 L	External setpoint Example: 0-5 V	0 V	2.5 V	5 V
5 L	Threshold current limit (optional)		0 to 10 V	
6 L	Current image for PLF detection	0 V	Modulation 0 to (-4.6 V)	- 4.6 V
7 L	Load voltage image	0 V	Modulation 0 to (-4.3 V)	4.3 V
8 L	Control setpoint	0 V	-2.5 V	- 5 V
9 L	Not used			
10 L	Firing demand	0 V _{mean} 1V _{peak}	Modulation 12.5 V peak	12.5 V
11 L	'+10V' reference		10 V ± 0.1 V	
12 L	Auxiliary supply image		- 24 V full wave rectified	
13 L	Pulse output	24V no pulses	24 V pulses	24V pulses
14 L	'-15 V' electronics supply		- 15 V ± 150mV	
15 L	Oscillator input	0 V	6.4 V _{peak}	1.2 V 6.4 V peak
16 L	'+15 V' electronics supply		+ 15 V ± 150mV	
17 L	'0' voltage crossing pulse		- 10.5 V ±12.5 V peak 0.6 ms	
18 L	Electronics supply 0 V		0 V	
19 L	Not used			
20 L	Enable		<- 10 V	

Table 6-2 Assignment of the positions of the EUROTHERM type 260 diagnostic unit Left diagnostic socket. All models.

All firing modes

Thyristor unit model	Position	Assignment	0 % of setpoint	100 % of setpoint
470, 471, 472	1 R	Load current image	0 V	AC signal 2.5 V RMS; 0 V mean
	2 R	Load voltage for control	0 V	AC signal 2.5 V RMS; 0 V mean
	3 R	Load voltage image	0 V	AC signal 2.5 V RMS; 0 V mean
	4 R	Power limit	True 13.5 V Not true 0 V	
	5 R	True power image (nominal load)	0 V	+ 10 V
	6 R	Current image for control	0 V	AC signal 2.5 V RMS; 0 V mean
	7 R	Power limit threshold	- 5 V for 100% threshold 0 V for 0% threshold	
	8 R	'-15V' electronics supply	- 15 V \pm 150 mV	
	9 R	Instant power image	0 V	Single-pole double frequency 2.5 V mean signal
472	10 R	Oscillator input	+ 24 V no pulses	+ 24 V pulses
470, 471, 472	11 R	Used during maintenance	-	
	12 R	'+15V' electronics supply	- 15 V \pm 150 mV	
472	13 R	Gate pulses of thyristor T1	+ 24 V no pulses	+ 24 V pulses
	14 R	Used during maintenance	-	
	15 R	Gating input of thyristor T2	AC signal, 1 st half-cycle positive	
	16 R	Gate pulses of thyristor T2	+ 24 V no pulses	+ 24 V pulses
	17 R	Pulse oscillator	No pulses	+ 24 V pulses
470 to 472	18 R	Electronics supply 0 V	0 V	
472	19 R	Gating input of thyristor T1	AC signal 1 st half-cycle negative	
	20 R	'+24V' electronics supply	+ 24 V (+0.2 V; -4 V)	

Table 6-3 Assignment of the positions of the EURO THERM type 260 diagnostic unit
Right diagnostic socket

In positions 1R, 2R, 3R and 6R, the **RMS values** can be measured with an external voltmeter connected to the oscilloscope terminals of the diagnostic unit.

CALIBRATION

When it leaves the factory, the thyristor unit is set for the **nominal** voltage and the **nominal** load current determined by the corresponding codes.

In this condition, the **nominal** power corresponds to 100% of the feedback signal; the true power image (available at terminal **36** of the driver terminal block or in position **5R** of the diagnostic unit) is + **10 V**.

For the real application, the dissipated power in the load can be different to the nominal power (power supply voltage slightly different to that of the thyristor unit, nominal load current different to the nominal current of the thyristor unit specified in the unit order, tolerance of installation components).

In this case, the feedback and the retransmission signal do not correspond to the true power value.

To calibrate the thyristor unit to operating conditions, the user can adjust the feedback values and the power image using the calibration potentiometer labelled '**P.Adjust/P.Régl**' on the front panel of the thyristor unit.

The value retransmitted at terminal **36** of the driver board terminal block (or in position **5R** of the diagnostic unit connected to the Right connector) can be adjusted to **10 Vdc** exactly for the nominal power of the load used.

The value read in position **9R** of the diagnostic unit is **2.5 V** mean for the nominal calibration.

PRELIMINARY SETTINGS

The preliminary setting is used to adapt the first thyristor firings to the type of load used.

- For resistive loads **with low resistance variations**, firing at zero voltage does not generate steep voltage fronts, thus minimising the electromagnetic interference produced.
- For resistive loads **with high resistance variations**, use of the 'Burst firing' modes with soft start reduces the current requirement when the load is cold with a low resistance ('Current limit' option must be used).
- For **non-saturating inductive and transformer connected** loads, delayed first firing eliminates the transient over-current (see 'Operation' chapter).
This delay can be adjusted between **0** and **90°** and only acts on the first half-cycle.

The preliminary setting is carried out using potentiometer **P4** located on the control board (see figures 4-1 and 4-3).

To access the setting potentiometer, the unit must be **unplugged** from its backplate.

Warning !



Dangerous live parts are accessible when the unit is unplugged. Only a qualified person, authorised to work in a low voltage industrial electrical environment, should access the inside of the unit.

The effect of the setting potentiometer depends on the thyristor firing mode.

Thyristor firing mode	Action of potentiometer P4
Phase angle	No action
Single cycle Slow cycle Fast cycle	Delayed first firing of the thyristors at the start of each firing cycle
Burst firing with soft start	Soft start duration in thyristor firing angle variation
Burst firing with soft start and end	Soft start and end duration in thyristor firing angle variation

Table 6-4 Effect of the preliminary setting potentiometer

Default position of potentiometer P4

When it leaves the factory, the potentiometer 'P4' is set as shown below.

Thyristor firing mode	Position of potentiometer P4
Fast cycle Slow cycle Single cycle	Turned fully anti-clockwise (Zero delay)
Soft start Soft start and end	Turned fully clockwise (Maximum ramp)
Phase angle	No action

Table 6-5 Default setting of potentiometer P4

Resistive load with low resistance variations

For loads with low resistance variations as a function of temperature, use the 'Single cycle' or 'Burst firing' thyristor firing modes.

The preliminary setting must guarantee thyristor firing at zero voltage.

- Ensure that potentiometer **P4** on the control board is turned completely anti-clockwise (delay angle = **0** and ramp absent, see table 6-5).
- Switch on the thyristor unit.
- On the external input (terminal **4** of the control terminal block), apply a signal corresponding to **0%** of the control signal.
Using an ammeter, measure the RMS current and check that the load current does not pass.
- On the external input (terminal **4**) or manual input (terminal **5**), apply a signal corresponding to **100%** of the control signal.
Using an ammeter, measure the RMS current and check that the current is equal to the nominal load current.

Resistive load with high resistance variations

For loads with high temperature coefficients, use the Phase angle thyristor firing mode or the soft start with the 'Current limit' option.

For the soft start, the ramp is **set** to approximately **300 ms** (the ramp setting potentiometer P4 has no effect).

Non-saturating inductive load

When the load has an inductive component (a 50 Hz inductor, for example), firing at zero voltage in the 'Burst firing' or 'Single cycle' firing modes generates transient operation which produces an over-current and in some cases can cause the thyristor protection fuse to blow (see 'Operation').

To avoid these over-currents at the start of each burst, the first firing of the thyristors must be **delayed** in relation to the corresponding zero voltage.
(Phase angle firing mode can also be used).

The **optimum** delay angle (90° max) must be **adjusted** with potentiometer '**P4**' depending on the **load used**. The delayed thyristor firing only affects the first firing in each burst.

To set for a non-saturating inductive load:

- Turn potentiometer '**P4**' completely clockwise (maximum delay equal to 90°).
- Set a control signal corresponding to approximately 20 % of the maximum setpoint.
- Slowly turn potentiometer '**P4**' anti-clockwise in order to reduce the over-current (visible on the oscilloscope screen) at the beginning of each burst as much as possible.

Saturating inductive load

When controlling a **saturating** inductive load (e.g. transformer primary with a resistive load having a low resistance variation on the secondary), use the 'Burst firing with soft start' firing mode with **no** current limit.

The soft start (or start and end) time is set using potentiometer **P4** on the control board, for the following following thyristor firing modes:

- slow or fast cycle with soft start
- slow or fast cycle with soft start and end

The soft start (or soft start and end) can be adjusted from **0** to **250 ms**.

The maximum ramp is obtained with potentiometer '**P4**' turned completely **clockwise**.

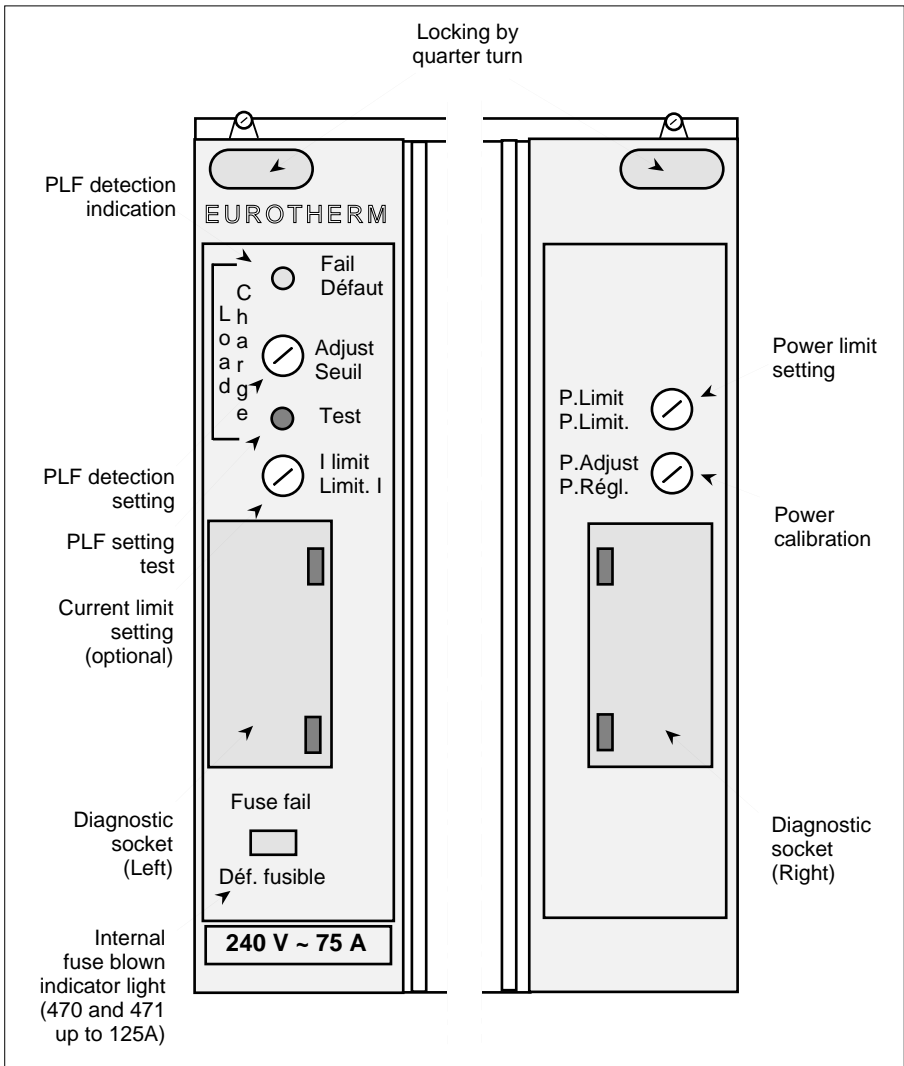

Figure 6-2 Front panel of the 470 series thyristor unit

PARTIAL LOAD FAILURE DETECTION SETTING

The partial load failure (PLF) detection is adjusted using the potentiometer labelled '**Adjust/Seuil**' on the front panel (see figure 6-2).

The purpose of this setting is to adapt the PLF detection with the maximum sensitivity to the real thyristor unit load.

To guarantee correct operation of the PLF detection circuit, the load current must not be less than **10 %** of the thyristor unit nominal current (in the case of use of a bulb as a load for a thyristor unit test in the workshop, the PLF detection indicator light '**Fail/Défaut**' is always lit).

During commissioning, the following setting must be made:

- First of all, make sure that the thyristor unit is connected correctly and that the thyristors are in permanent firing mode.
- Turn the PLF detection adjustment potentiometer completely **anti-clockwise** and check that the '**Fail/Défaut**' indicator light on the front panel is off.
- Turn the '**Adjust/Seuil**' potentiometer slowly **clockwise** until the indicator light comes on.
- Turn the potentiometer slowly anti-clockwise until the '**Load Fail**' indicator light has just gone off.

The potentiometer set in this way is used to obtain maximum sensitivity for the partial load failure detection really connected with the thyristor unit.

The push button on the front panel (labelled '**Test**') which simulates a current drop in the load is used to check the operation of the PLF circuit without having to disconnect the load. This button should place the thyristor unit **in the alarm state** if the setting has been performed correctly.

Reminder:

The PLF detection circuit does not use the load voltage directly, but recreates it electronically using the auxiliary supply voltage.

CURRENT LIMIT SETTING (OPTIONAL)

The current limit can be adjusted using the '**I limit / Limit.I**' potentiometer on the front panel.

- Make sure that the load is connected.
- When the threshold current limit is used in cascade with an external potentiometer or signal, make sure first of all that the 'Threshold limit' setpoint (**10 V** in position **5L** of the diagnostic unit) is at the maximum value.
- Turn the '**I limit / Limit.I**' current limit potentiometer completely **anti-clockwise** (**minimum** current).
- Apply a **0 V** signal to terminal **14** and connect the power voltage.
The RMS voltage at the load terminals must be zero.
- Increase the current limit input signal to 100 % ('**I limit / Limit.I**' potentiometer still turned completely **anti-clockwise**).
The load voltage should not increase.
- Turn the '**I limit / Limit.I**' potentiometer gradually clockwise and check that the current rises slowly. Set the '**I limit / Limit.I**' potentiometer in order to obtain the maximum current **permitted** by the load: **I_{LIM}**.

Caution !



- For the current limit setting, only use an ammeter which gives the **True RMS** value to measure the load current in order to prevent risks of errors which may reach 50 % and make sure that the setpoint is 100%.
- The threshold current limit can be **pre-set** when a thyristor unit is switched on but **not firing**.

The value of the **squared** RMS load current is **proportional** to the Threshold current limit' setpoint observed at position **5L** of the diagnostic unit.

The current limit voltage **V_{5L}** can be calculated using the following equation:

$$V_{5L} \text{ (V)} = 8.26 \text{ V} \frac{I_{LIM}^2}{I_{NOM}^2}$$

Current limit signal (position 5L of the diagnostic unit)	I_{rms}^2 (%)	I_{rms} (%)
10 V	121	110
8.26 V	100	100
6.69 V	81	90

Table 6-6 Example of the threshold current limit

POWER LIMIT

The power limit (of the controlled parameter) can be adjusted using the '**P.limit**' potentiometer on the front panel.

- Make sure that the load is connected.
- Turn the '**P.limit**' potentiometer completely clockwise.
- Set the (external or manual) control signal to zero.
Connect the thyristor unit supply voltage.
Check that the thyristors are not outputting (with an ammeter or with the diagnostic unit displaying the load current and voltage images as zero).
- Adjust the current limit to **100%**.
Adjust the power limit setpoint to **20%** (**-1 V** in position **7R** of the diagnostic unit, connected to the Right socket).
- Gradually increase the control signal to **100%** and check that the thyristors output the current.
The power image should correspond to **20%** of the calibrated value (**2 V** in diagnostic position **5R**).

For each load, the voltage of the required power limit can be calculated (voltage in position **7R** of the diagnostic unit - V_{7R}) if the following parameters are available:

Nominal thyristor unit voltage	- V_{UN} (V)
Nominal thyristor unit current (after calibration)	- I_{UN} (A)
Maximum power allowed by the load	- $P_{L.MAX}$ (W)

The voltage V_{7R} of the diagnostic unit should be set to:

$$V_{7R} \text{ (V)} = (-5 \text{ V}) \cdot \frac{P_{L.MAX}}{V_{UN} \times I_{UN}}$$

If the controlled parameter is V^2 and the maximum voltage allowed by the load is $V_{L.MAX}$, the voltage V_{7R} should be set to:

$$V_{7R} \text{ (V)} = (-5 \text{ V}) \cdot \frac{V_{L.MAX}^2}{V_{UN}^2}$$

CHECKS IN THE EVENT OF ABNORMAL OPERATION

Symptom	Action
1. The thyristor unit is not fired after a firing demand.	<p>1.1. Check that the power is present (if the power is absent but the electronics supply voltage is present, the thyristor unit indicates a PLF alarm and the indicator light on the front panel is lit).</p> <p>1.2. Check the state of the thyristor protection fuse.</p> <p>1.3. Check the connection of the auxiliary supply on the user terminal block (terminals 51 and 52 or 53).</p> <p>1.4. Check that the electronics supply is present (presence of +15V, -15V, +10V, +24V voltages, see tables 6-1 to 6-3)</p> <p>1.5. Check that the 'Inhibit' input (terminal 16 on the control board) is not connected to '+10 V' (terminal 12).</p> <p>1.6. Check that terminal 21 and 22 on the driver board ('Safety quench') are correctly interconnected.</p> <p>1.7. Check that the control signal arrives correctly on the control board terminal block (terminal 4 or 5), the signal polarity is correct (negative voltage in position 8L) and that the control wires are correctly inserted in the screw connection system.</p> <p>1.8. Check that the input signal type and level are compatible with the type and level of the configured signal.</p> <p>1.9. Check the wiring of the thermal switches (471 and 472 models).</p> <p>1.10. Check the presence of the thyristor firing pulses (diagnostic position 13L for the 470 and 471 models; position 17R for the 472 model).</p> <p>1.11. Check that the current limit is not at zero (diagnostic positions 5L and 4R).</p> <p>1.12. Check that the power supply voltage is greater than or equal to 70 % of the thyristor unit nominal voltage.</p> <p>1.13. Check that the 'Gate-Cathode' wires are not inverted (472 model).</p>

Symptom

Action

2. The transient over-current when starting up an inductive load is too high (Burst mode or Single cycle firing).

- 2.1. Check that the load wiring is correct.
- 2.2. The factory pre-setting of potentiometer **P4** of the delayed firing angle is **0°**. Increase this angle by turning potentiometer '**P4**' clockwise.

3. The thyristor is in full firing with an input signal at zero.

- 3.1. Check the configuration of the input signal and the controlled parameter and that the signal is really absent from terminals **4** and **5** of the control terminal block.
- 3.2. By disconnecting the 4 'Gate-Cathode' wires (**472** model) and isolating the connection lugs, check that the thyristors are not short-circuited. For the **470** and **471** models, use an ohmmeter to check that the thyristors are not short-circuited **after disconnecting** the unit.
- 3.3. Check that the electronics supply voltage is connected correctly and is in phase with the power.

4. The thyristor unit remains in partial firing after the input signal has been applied and set to zero (power control only).

- 4.1. Check the polarity of the power indications (diagnostic positions **5R** and **9R**). If these indications are negative, one of the 2 measurements (load current or voltage) is inverted and the thyristor unit measures a negative power. Check that the load voltage information connection (terminals **61** and **63**) is correct. For the **472** model, check the polarity of the connection of terminals **38** and **39** (external thyristor current measurement).

Note the voltage of the 40 diagnostic positions at the 0% and 100% setpoint, this often indicates the cause of the failure.

If the fault persists after all these checks, contact your nearest EURO THERM office, where technicians will be able to advise you and assist you during commissioning.

Chapter 7

MAINTENANCE

Contents	Page
Thyristor protection	7-2
Thyristor protection fuse	7-3
Replacement of the internal high speed fuse	7-4
Auxiliary power supply protection fuses	7-4
Servicing	7-5
Tools	7-6

Chapter 7 MAINTENANCE

Warning !



The thyristor unit must be maintained by qualified personnel, authorised to perform work in a low voltage industrial electrical environment.

THYRISTOR PROTECTION

The thyristors of the **470** series power units are protected as follows:

- the internal high speed fuse against over-currents
- the RC snubber circuit and the varistor against excessively fast voltage variations and transient over-voltages when the thyristors are not firing.
- the thermal switch for the **471** model and for the external thyristor block (**472** model)

In the event of accidental overheating of the cooler or if the fan stops, the thermal switch opens, which causes the thyristor firing to be stopped.



Warning !

- The internal thyristor protection fuse (**470** and **471** models) does not **protect the installation** in any circumstances.
 - The external thyristors driven by the driver unit (**472** model) should be protected by following the connection and safety instructions in the thyristor block manual.
 - The user's installation must be **protected upstream** (non high speed fuse, thermal or electromagnetic circuit breaker, appropriate fuse and fuse-holder assembly) and must comply with current standards.
-

THYRISTOR PROTECTION FUSE

The **470** and **471** model thyristor units are supplied with the **internal** fuse (up to 125 A) with fuse blown indicator light.

For the **150** Anominal current (471 model), the **external** fuse must be ordered separately.



Caution !

The high speed fuse is only used for the internal protection of **the thyristors** against wide amplitude over-loads.

Table 7-1 contains all the part numbers of the original internal fuses (as fitted in the factory) and the fuses which are authorised for replacement during maintenance.



Caution !

The use of other fuses **invalidates the thyristor unit guarantee.**

Model	Nom. current	Max. voltage	Part Numbers				
			Eurotherm	Suppliers			
				Ferraz	I.R.	Brush	G.E.C
470	75 A Internal fuse	500 V	CH 120114	B 099959	EE 1000.110	110 EET	GSG1000.110
471	125 A Internal fuse	500 V	CH 120154	C 099960	EE 1000.150	150 EET	GSG1000.150
	150 A External fuse	500 V	CH 340025	H 300019	–	–	–
	150 A Fuse-holder	–	CP 171482	V 98711	–	–	–
472	External thyristor block	Protection of external thyristors according to thyristor block supplier recommendations.					

Table 7-1 Recommended high speed fuses for thyristor protection

REPLACEMENT OF THE INTERNAL HIGH SPEED FUSE

The **470** and **471** model power thyristor units (nominal current from 15 to 125 A) are fitted with **internal** high speed fuses.

These fuses are mounted at the rear of the plug-in unit.

If the internal fuse **blows**, a **red indicator light** on the front panel of the unit lights up.

To replace the internal fuse:

- unplug the unit from its backplate
- loosen the two fuse attachment screws (see figure 4-1)
- fit the appropriate fuse (the part numbers are given in table 7-1).

Tightening **3.5 N.m**.

Caution !



The thyristor unit may be damaged if tightening is not performed correctly.

For the **150 A** nominal current (**471** model), the high speed fuse and its holder are **external**.

AUXILIARY POWER SUPPLY PROTECTION FUSES

These fuses should be installed in the cables which connect the auxiliary power supply voltage (see 'Wiring' chapter).

Auxiliary voltage (max)	1 A fuse 6.3 x 32 mm	Fuse and fuse-holder assembly	'Fuse and fuse-holder' assembly dimensions (mm)
500 V	CS174289U1A0	CP174293	63 x 15 x 52

Table 7-2 Recommended fuse for protection of the auxiliary power supply connection

SERVICING

The **470** series thyristor units must be mounted with the heatsink vertical, with no obstructions above or below which could reduce or hinder the air flow.

Caution !



If several units are fitted in the same cabinet, arrange them so that the air from one unit **is not taken in** by the unit placed above it.

For correct cooling of the unit, it is recommended that the **heatsink** and the fan protection **mesh** be **cleaned** periodically, depending on the degree of pollution of the environment.

Warning !



Every **six months**, check that the screws holding the power cables and the safety earth are correctly **tightened** (see "Wiring").

TOOLS

Operation	Flat screwdriver (mm)	Wrench	Electrical equipment
Attachment of the backplate	Depending on M4 screw heads selected		
Safety earth connection	1 x 6 (470 and 472) 1 x 8 (471)		
Power connection (power supply side) and load connection	1 x 8 (470 and 471)	HEX17 M10 (471)	
Internal thyristor fuse replacement	2 x 15		
Cable clamp tightening	0.5 x 3.5		
Control and auxiliary power supply voltage connection	0.5 x 3.5		
Commissioning and setting	0.4 x 2.5		RMS ammeter or clip. Eurotherm type 260 diagnostic unit recommended.

Table 7-3 Tools