

Circuit board retrofit instructions

180 mm Paperless graphic recorders

INTRODUCTION

These instructions are intended to help service engineers and others to add or replace 180 mm recorder circuit boards. The instructions apply to the power supply unit, as well as to input boards and option boards, including serial comms. and USB options. For all other replacement and or retrofit instructions, including the main (micro) board and the display inverter board, refer to HA028909U180.

WARNING!

Isolate the recorder from all hazardous voltage sources, both supply and signal. Allow the recorder to cool for at least 10 minutes after powering off.



CAUTION

These procedures involve the handling of components which are sensitive to static electrical discharge. All relevant personnel must be aware of static handling procedures.

Note: The illustrations in this document show the addition of an eighth input board, and the ninth option board to a recorder already fitted with seven input boards and eight option boards. The procedure for fitting other boards is similar, the difference being in the organisation of the flexi-cable chain, and in the setting of the switches and links which define board number.

BOARD LOCATION RULES

1. If Relay output boards are fitted, they must be located in the lowest numbered slots.
2. Relay board types must be fitted in the order: Change-over, Normally-closed; Normally-open.
3. If Event input boards are fitted, they must be fitted in the lowest numbered slots which are available after all relay boards have been fitted.
4. If analogue output boards are fitted, they must be fitted in the lowest numbered slots which are available after all relay and Event input boards have been fitted.

i n v e n s i s
Eurotherm

EUROTHERM LIMITED
Faraday Close, Durrington, Worthing, West Sussex, BN13 3PL
Telephone: +44 (0)1903 268500 Facsimile: +44 (0)1903 265982
e-mail: info.uk@eurotherm.com
Website: <http://www.eurotherm.co.uk>

FLEXI CABLE ORGANISATION

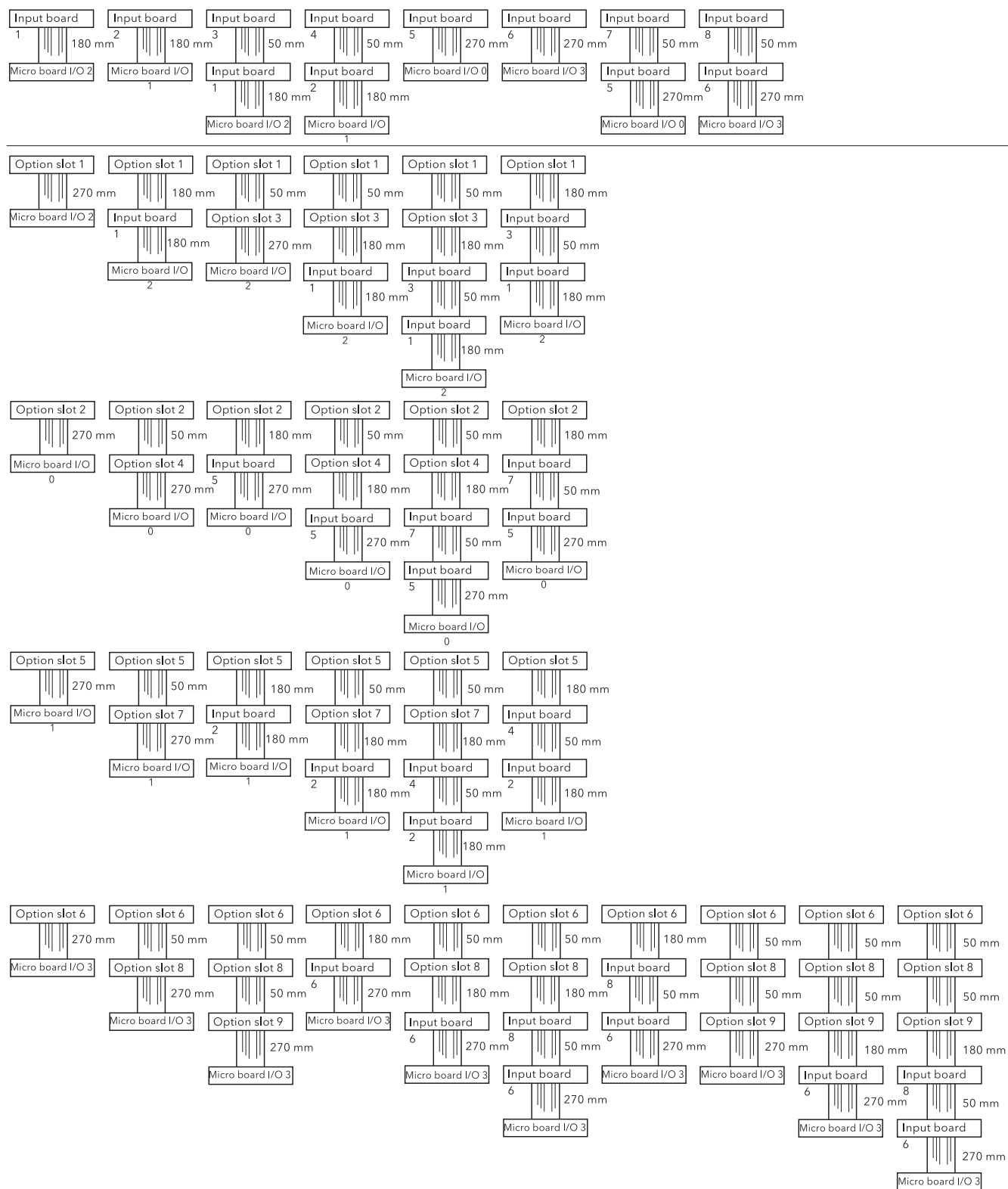

18

USB OPTION RETROFIT

Following on from instruction 17:

If this is the first time a USB option has been fitted, peel off the self-adhesive label ('e') covering the apertures, for the USB connectors, in the rear panel.

If not already fitted, insert two plastic stand-off pillars ('b') to the Battery/Ethernet/Serial comms board.

19

Fit the USB board onto the stand-off pillars, ensuring that the connectors face the rear panel.

Secure the USB board using the four screws ('f') and sprung washers.

Connect the USB harness.

Re-assemble the recorder.

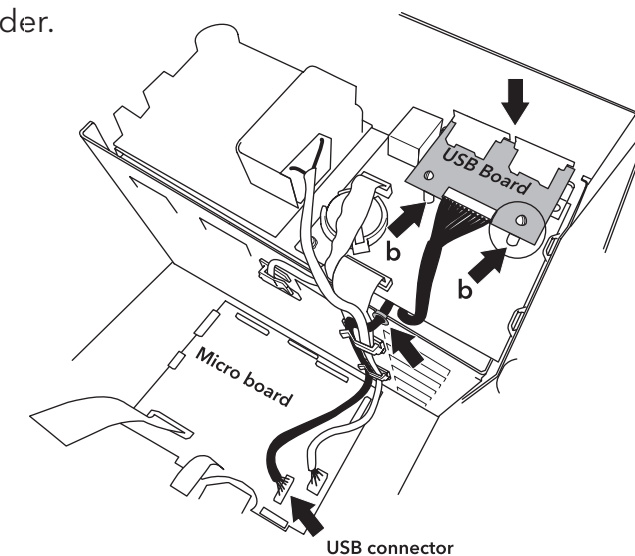
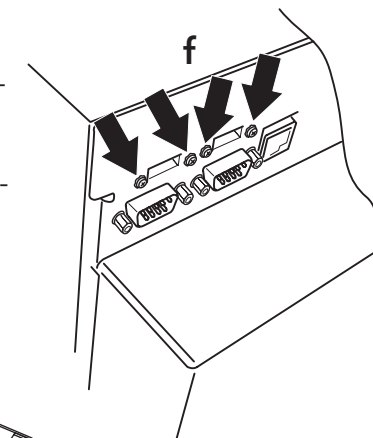
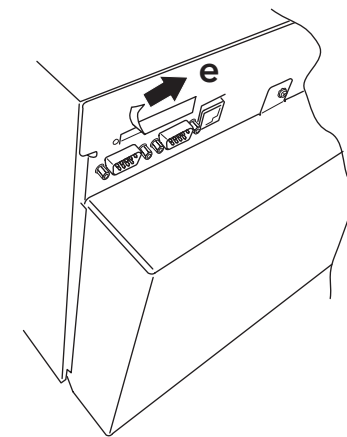

17

SERIAL COMMUNICATIONS RETROFIT

If a USB board is fitted, remove it by:

- a. Unclipping the loom and disconnecting it from the micro board.
- b. Removing the four securing screws ('a') and associated spring washers.
- c. Compressing the top of the stand-off pillars ('b'), whilst easing the USB board up and away.

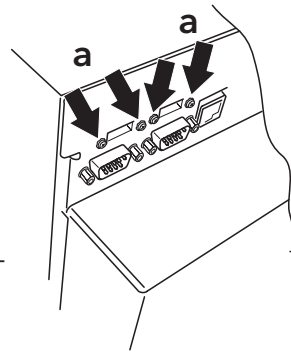

Place the board and associated loom/harness in a static safe area.

Disconnect the battery loom, and remove the battery.

Undo the two screws ('c') securing the Battery/Ethernet board to the chassis, and remove the board.

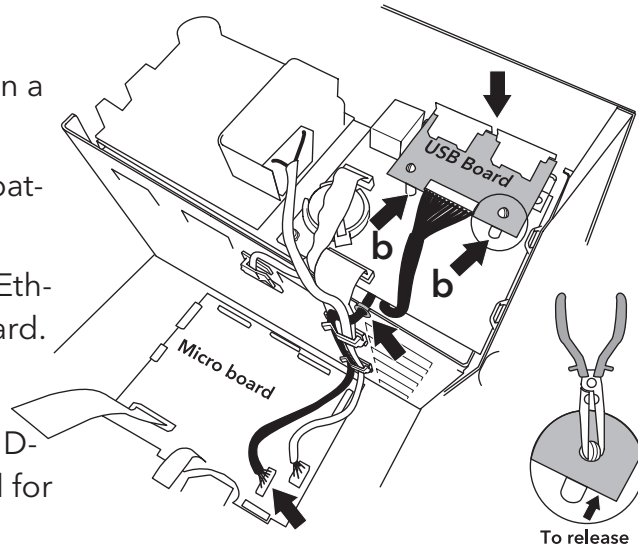

Lever out the blanking panels, filling the 9-way D-type apertures, in the same way as is described for 22-way connectors on page 4.

If a USB option is to be fitted, insert the two plastic standoff pillars ('b') into the new Serial communications board.

Slide the new board into the card cage, and secure it using the four hex jacking screws (d) and associated shake-proof washers, and the two screws 'c' previously removed. Fit either the battery previously removed, or a new battery.

Connect the serial communications flexi cable and the battery board harness to the serial communications board. Clip to the circuit board retainer as shown.

If the USB option is to be fitted, see instruction 19, otherwise, re-assemble the recorder.

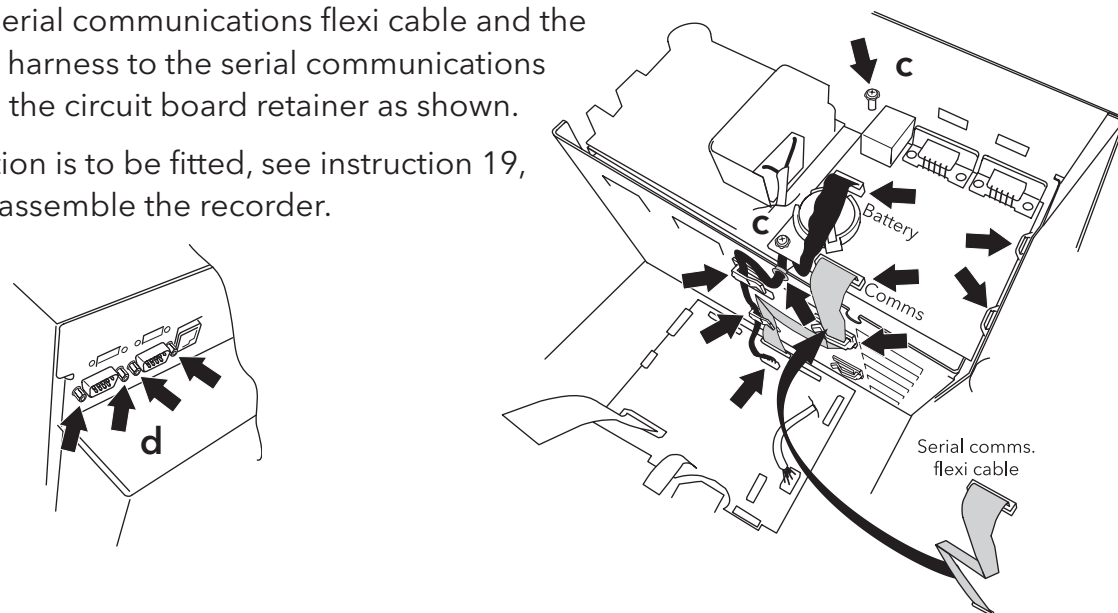

RELAY / EVENT INPUT BOARD SWITCH SETTINGS

Before fitting relay or event input boards, the two elements of the switch located near the front edge of the board must be set to define its board number. The figure below, and the accompanying tables give details. (Figure shows the relay board - the event input board is similar).

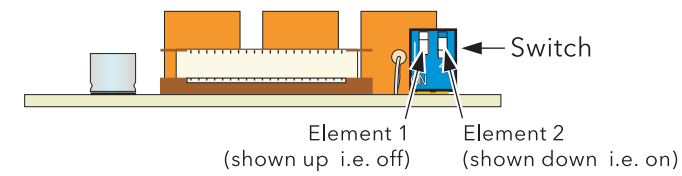

Relay board option slot	Switch element	
	1	2
1, 2, 5, 6	Up	Up
3, 4, 7, 8	Down	Up
9	Up	Down

Event input board number	Switch element	
	1	2
First	Up	Up
Second	Down	Up
Third	Up	Down
Fourth	Down	Down

INPUT BOARD LINK SETTINGS

Before fitting an input board, it is necessary to set the board address. The address is set by positioning links, as shown below.

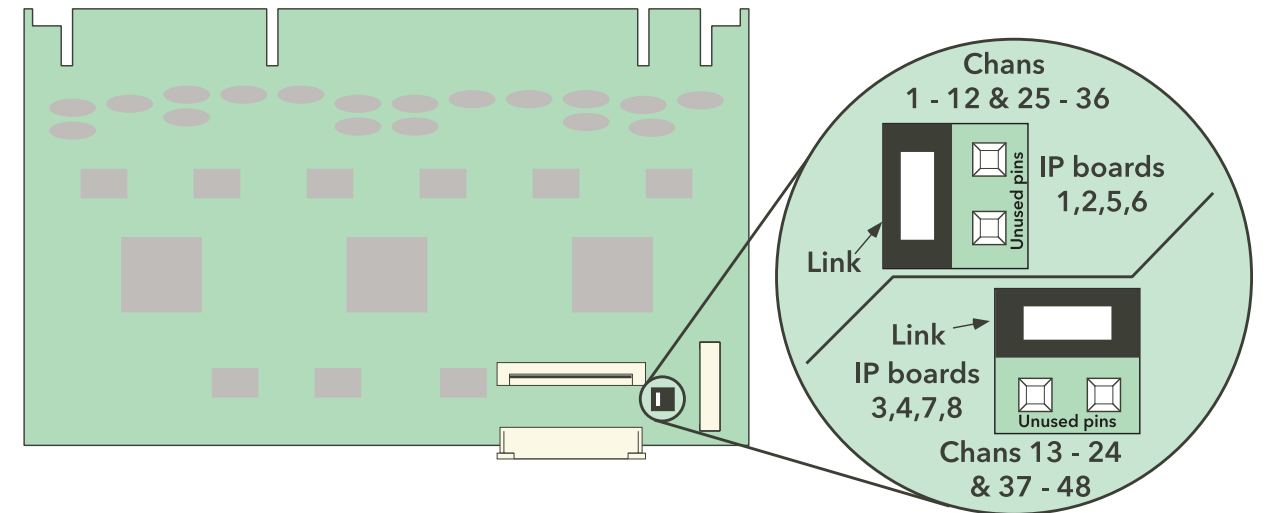

ANALOGUE OUTPUT BOARD LINK SETTINGS

Before fitting an analogue output board, it is necessary to set the board address according to which output board it is. The address is set by positioning links, as shown below.

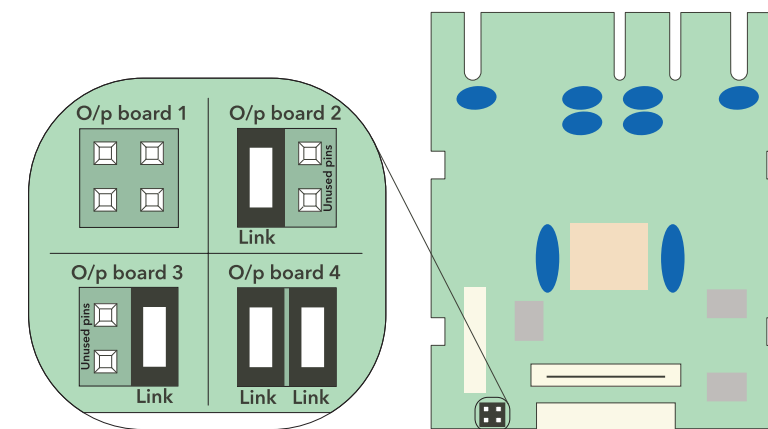

POLARISING PLUGS

In order to avoid accidental insertion of an incorrect board type, it is recommended that a polarising plug be inserted into the board side of the connector in the locations indicated in the table. Failure to do so may damage the recorder. As shown in the figure, the plug is inserted into the connector and the 'handle' is then snapped off.

Notes:

1. All relay board types have the same polarising key position
2. Input boards do not require polarising plugs.

Option board type	Insert plug between contacts:	
	Slots 1,3	Slots 2, 4
Analogue outputs	4 & 5	17 & 18
Event inputs	5 & 6	18 & 19
Relay outputs	6 & 7	19 & 20

Contacts are counted from the left end of the connector, as viewed from the rear of the instrument.

Insert polarising plug, then snap off 'handle'

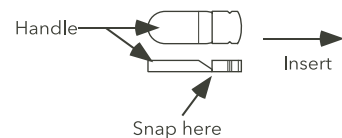

CONNECTOR LABELS

A set of self-adhesive labels (depicted below) is supplied, for the user to apply to the connector.

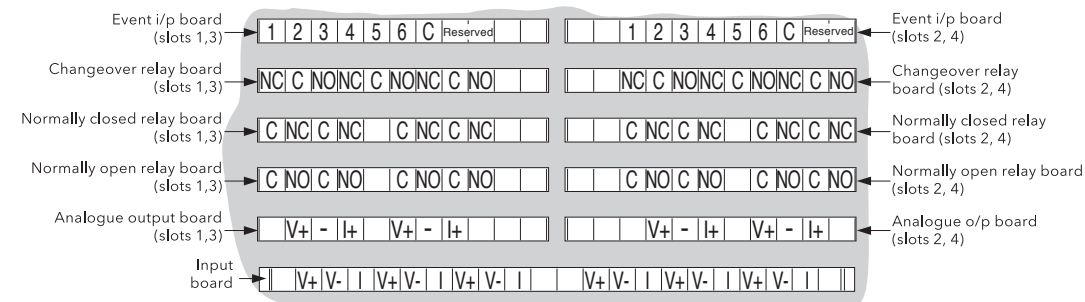

CONNECTOR FITTING

EMC springs must be fitted as shown.

Option boards require one EMC spring, fitted at the appropriate end of the connector slot.

Input boards require two EMC springs to be fitted, one at each end of the connector.

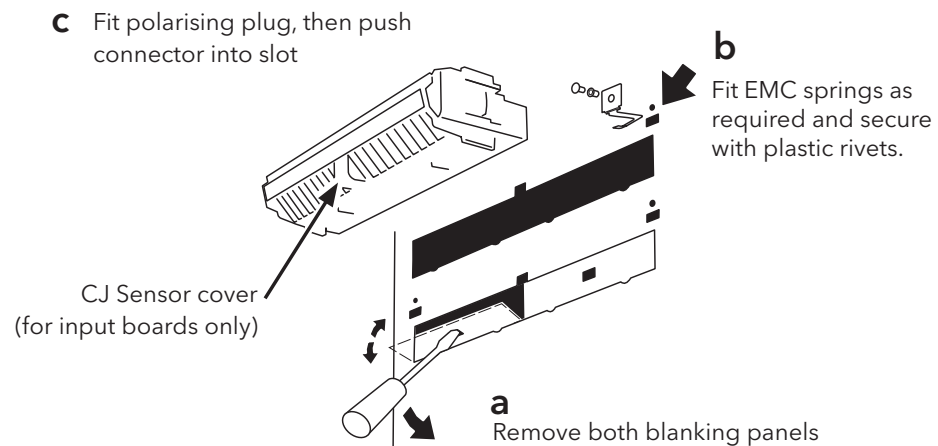

SERIAL COMMUNICATIONS AND USB OPTIONS

All recorders are fitted as standard with the 'Battery/Ethernet' board. To fit Serial communications, this Battery/Ethernet board is replaced by a similar board, which contains not only the battery and RJ45 Ethernet connector, but also all the necessary components and connectors for serial communications.

The USB option (if fitted) is mounted on plastic standoff pillars attached to the Battery/Ethernet board.

The following procedure assumes a USB option board is fitted, but the Serial communications option is not fitted. Should this not be the case, the user should ignore any irrelevant instructions.

17

With the recorder removed from the panel and isolated from supply power, remove the recorder top plate, by removing the four Torx-headed screws 'A' (two each side) and the pan-head pozidriv screw 'B' at the rear, then lifting the cover up and out from under the gasket 'C'.

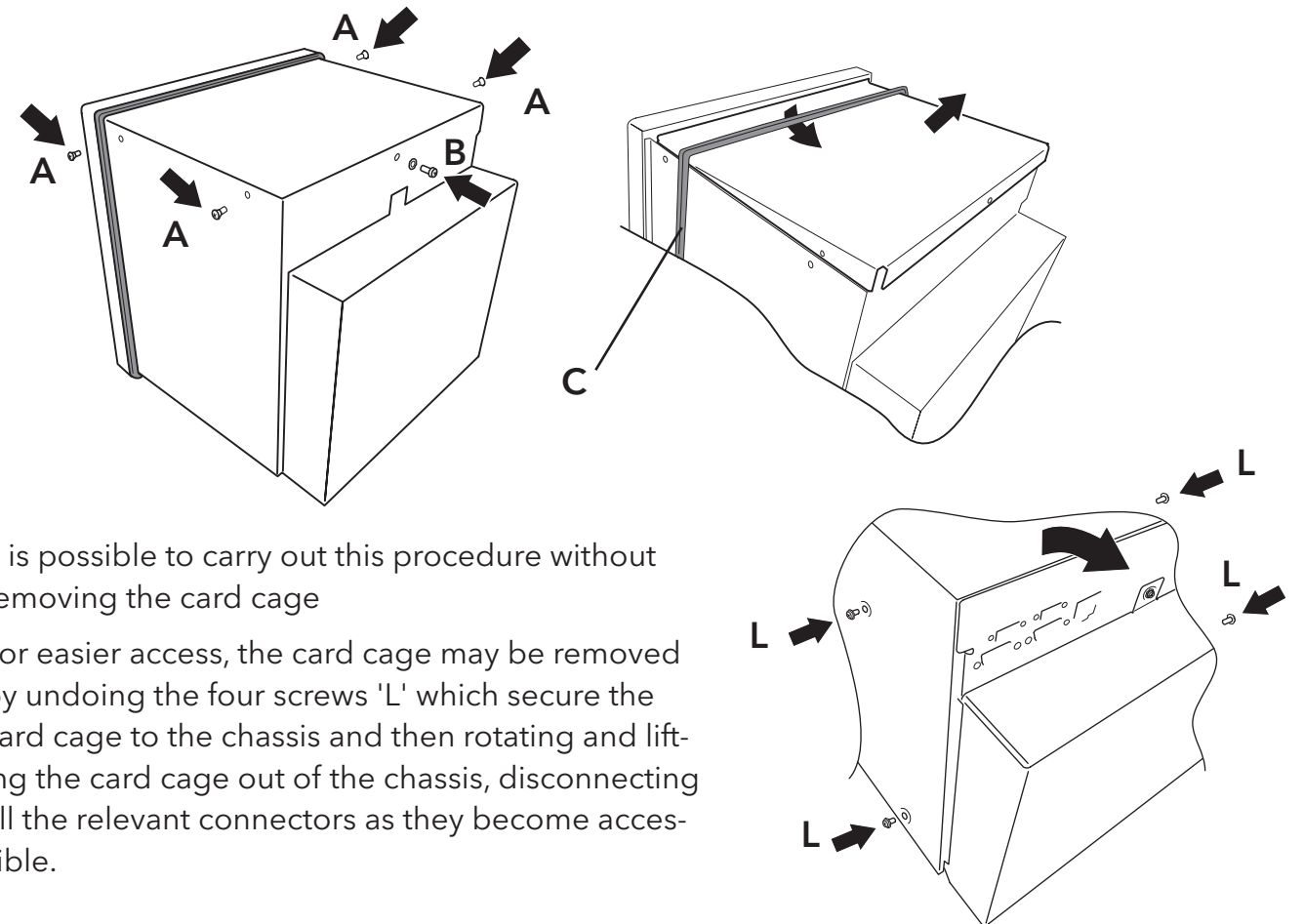

It is possible to carry out this procedure without removing the card cage

For easier access, the card cage may be removed by undoing the four screws 'L' which secure the card cage to the chassis and then rotating and lifting the card cage out of the chassis, disconnecting all the relevant connectors as they become accessible.

Note: It will be necessary to reset the time and date if the battery is disconnected.

AUTOCONFIGURE ACCESS

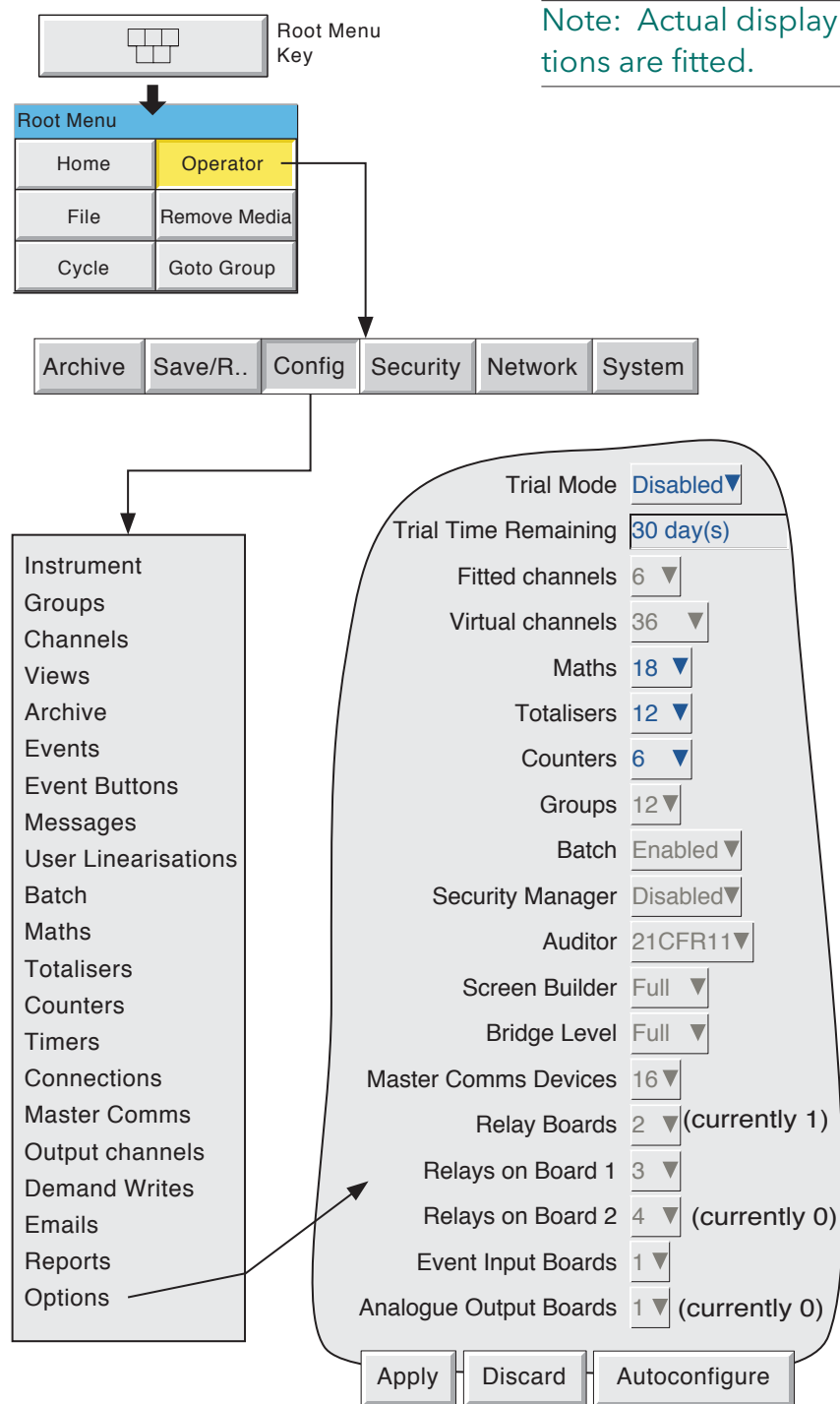

Note: Actual display depends on which options are fitted.

PSU REPLACEMENT

If the PSU is not to be replaced, please ignore this section, and start at instruction 7 instead.

- With the recorder removed from the panel and isolated from supply power, remove the recorder top plate, by removing the four Torx-headed screws 'A' (two each side) and the pan-head pozidriv screw 'B' at the rear, then lifting the cover up and out from under the gasket 'C'.

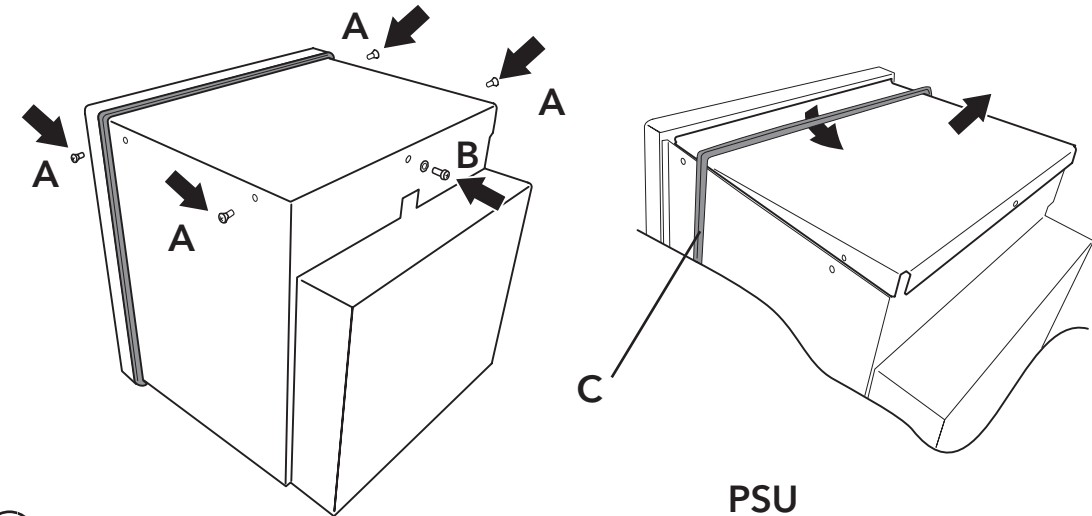

- Avoiding any hot components, carefully disconnect all the Power Supply Board connectors (D). (If the loom from the PSU to the micro board is to be replaced, this can be done now, remembering to secure the replacement using the clips 'F').

The PSU may be removed by undoing the four securing screws 'E'.

If the replacement PSU is of the same type as the existing one (i.e. the supply voltage is not being changed), the new PSU board can now be fitted, and secured using screws E, previously removed.

Reconnect all the connectors ('D') previously removed.

- If the replacement PSU is of a different type (e.g. low voltage instead of standard), continue at instruction 4.

If input or option boards are to be replaced, or retro-fitted, please continue at instruction 8.

If not, replace the recorder top and secure it using the 5 screws ('A' and 'B') previously removed.

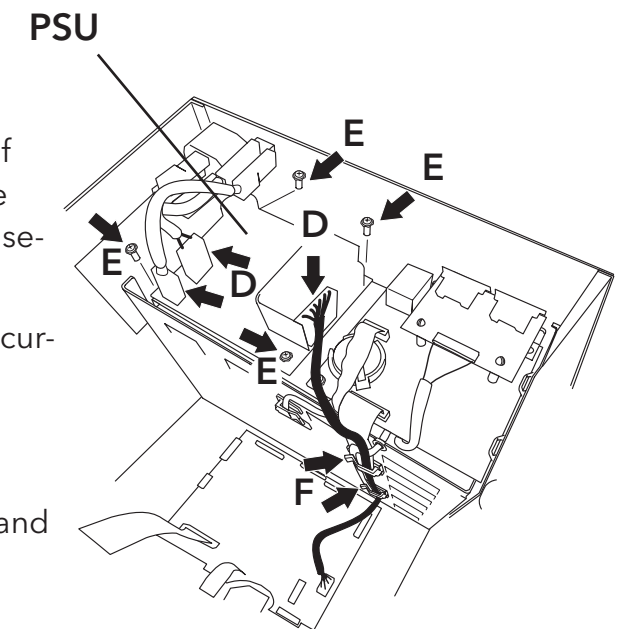

SUPPLY VOLTAGE CHANGE

Two versions of the power supply unit (PSU) are available, viz, Standard and Low Voltage. The standard unit accepts supplies of 85 to 265 Volts, 47 to 63 Hz ac, and 110 to 370Volts dc. The low voltage unit accepts ac supplies of 20 to 42Volts, 45 to 400 Hz, and dc supplies of 20 to 54 Volts.

When changing PSU versions, the existing supply voltage connector must be replaced with one suited to the supply voltage. This procedure is detailed below, for changing from the standard version to the low voltage version. The description should also be adequate for the situation where it is required, instead, to change from the low voltage version to the standard version.

4

Remove the power cord connector from the rear panel connector. Remove the existing PSU as described in instruction 2, above and fit the replacement physically, but without connecting it up.

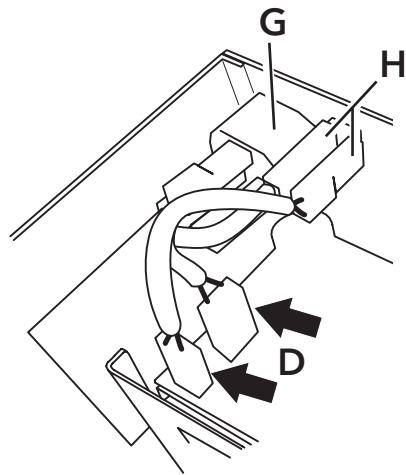

If necessary remove the connectors (D) from the PSU. Remove the old power harness by pulling off the push-on connectors on the back of the IEC plug ('G') and of the copper, 'U' shaped, bonding earth connection (H).

The IEC (mains) plug can now be removed from the rear panel, by pressing on the securing 'clips' or latches, on the top and on the underside of the connector.

5

Pass the rectangular connector and associated power leads through the support plate, then through the aperture in the rear panel and finally, through the backing plate. Secure the assembly with screws J.

Make the earth connections, and connect the power leads to the PSU.

Fit a new Supply Voltage label.

See 'Wiringdetails' on page 14 for dc wiring details.

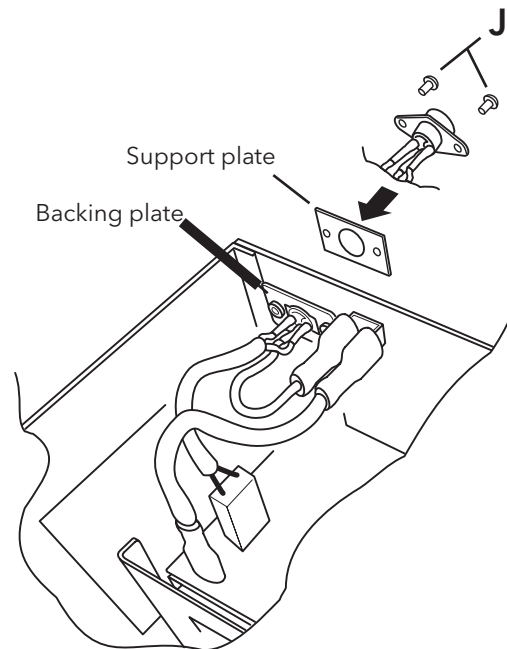

6

If input or option boards are to be replaced, or retro-fitted, please continue at instruction 8. If not, replace the recorder top and secure it using the 5 screws ('A' and 'B') previously removed.

WIRING DETAILS

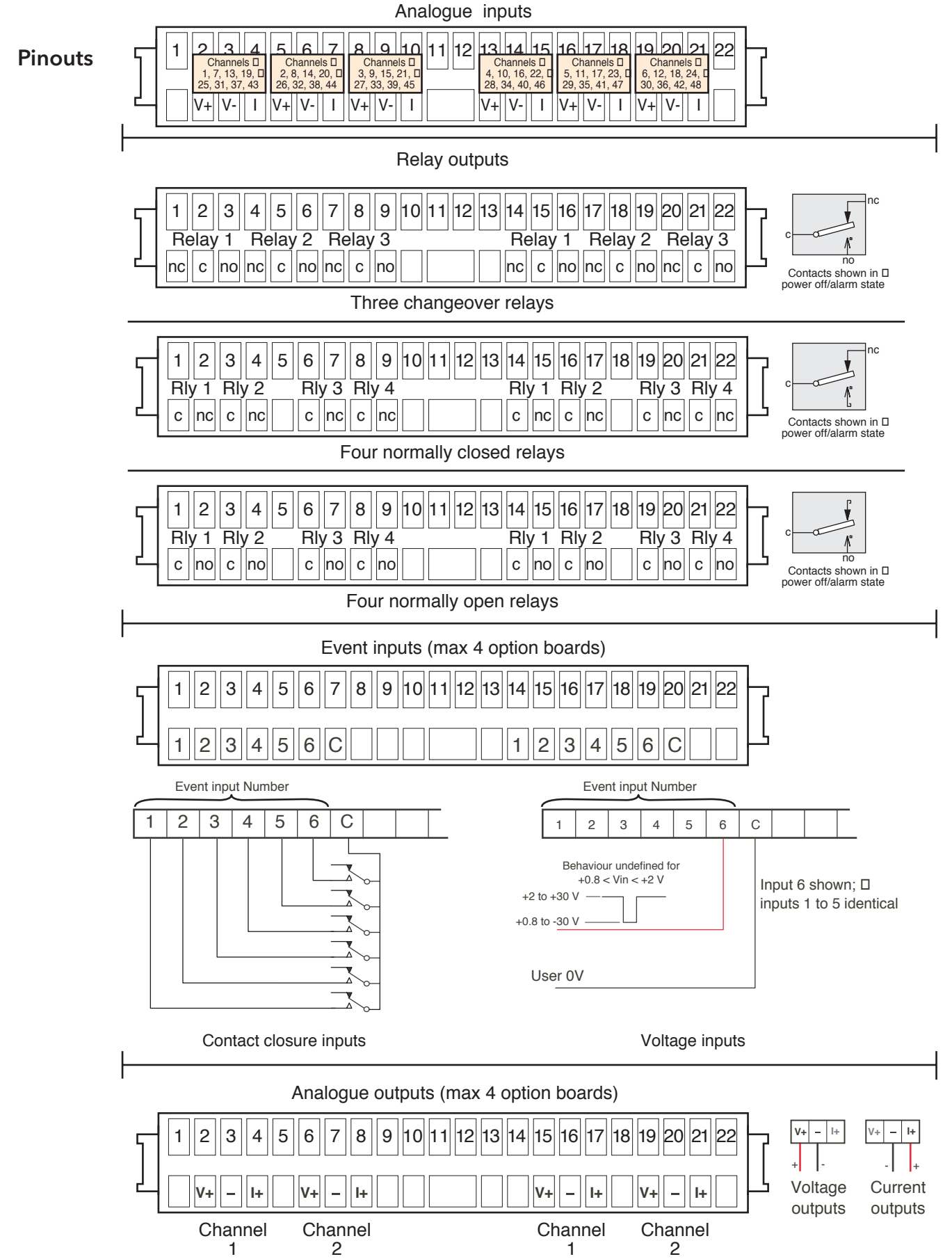

WIRING DETAILS

Connector locations

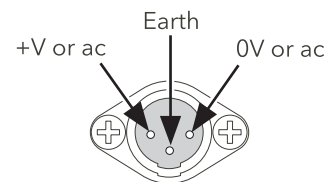
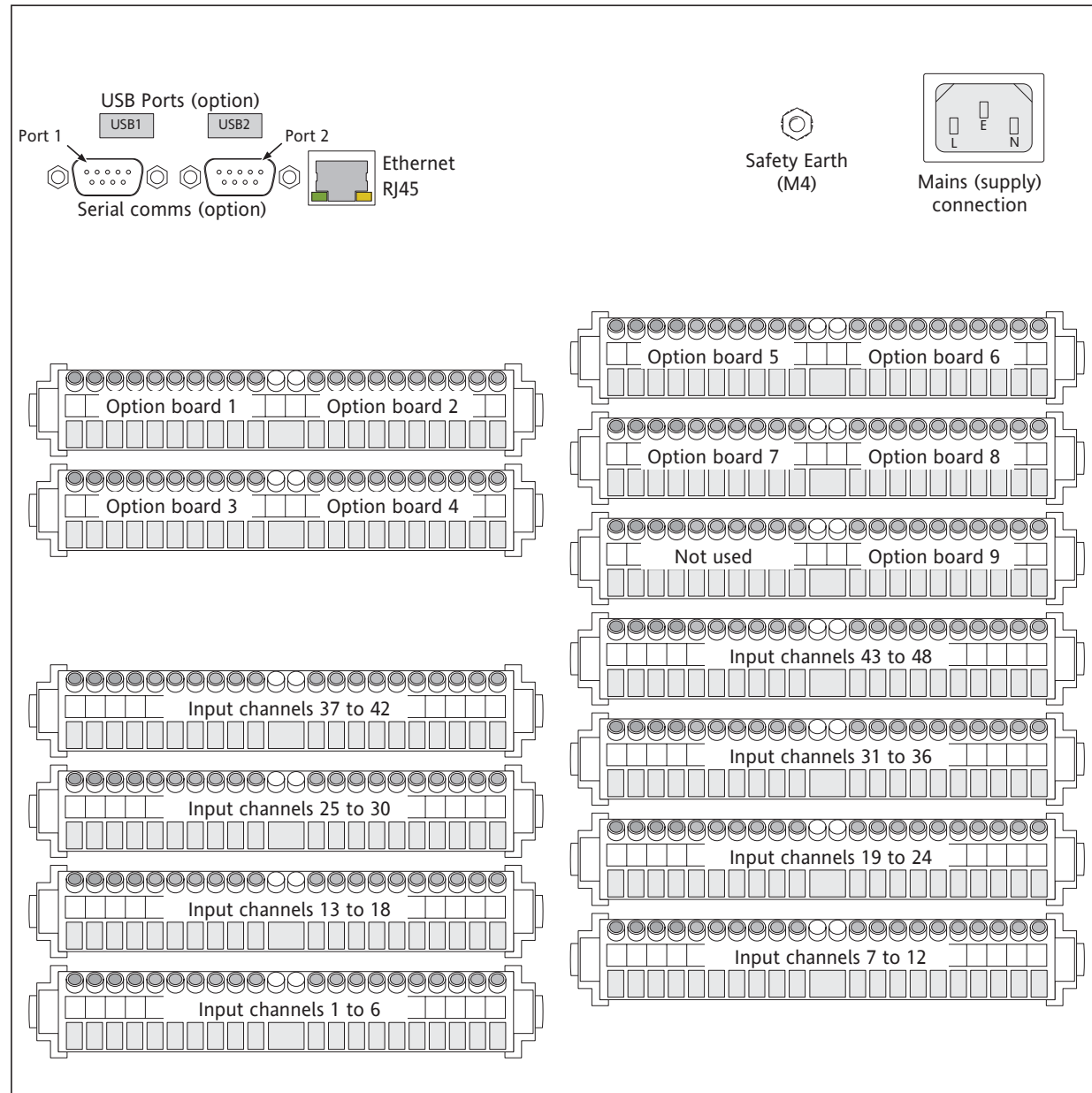

Supply power connection for dc supplies

7 With the recorder removed from the panel and isolated from supply power, remove the recorder top plate, by removing the four Torx-headed screws 'A' (two each side) and the pan-head pozidriv screw 'B' at the rear, then lifting the cover up and out from under the gasket 'C'.

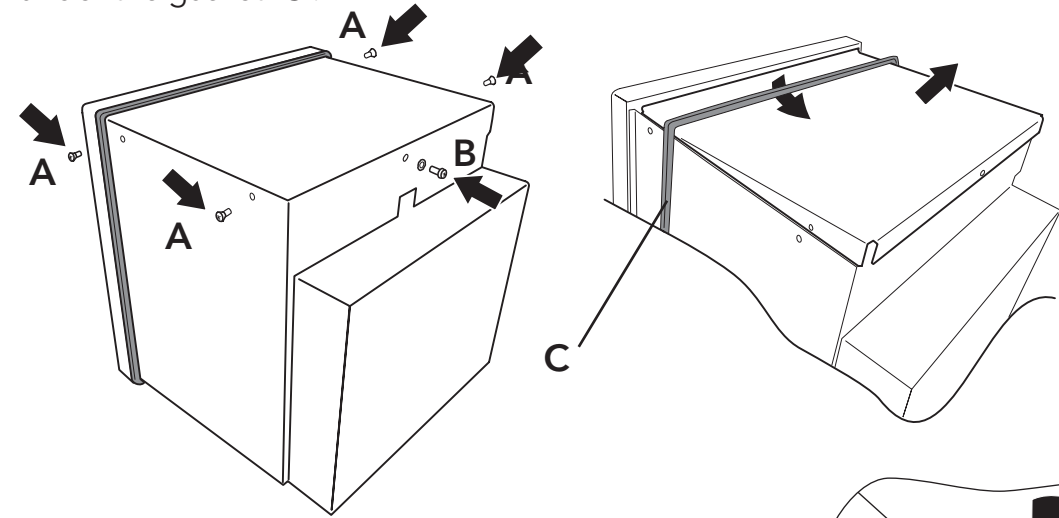

8 If necessary, remove the rear terminal cover, by undoing the (captive) securing screw 'K'. Undo the four screws 'L' which secure the card cage to the chassis. Rotate and lift the card cage out of the chassis, disconnecting all the relevant connectors as they become accessible.

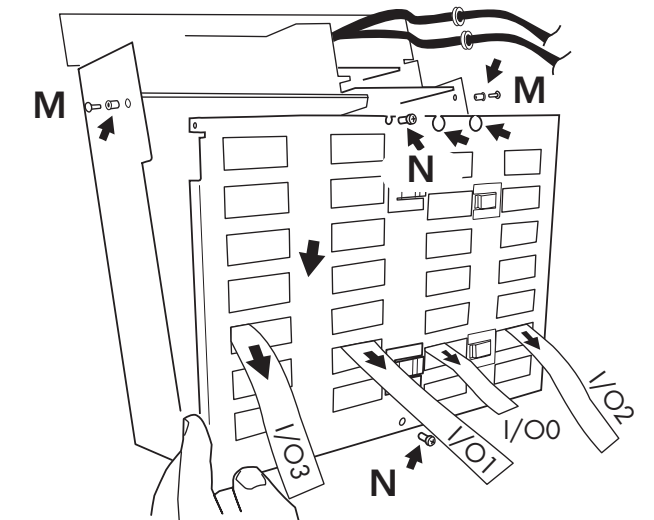
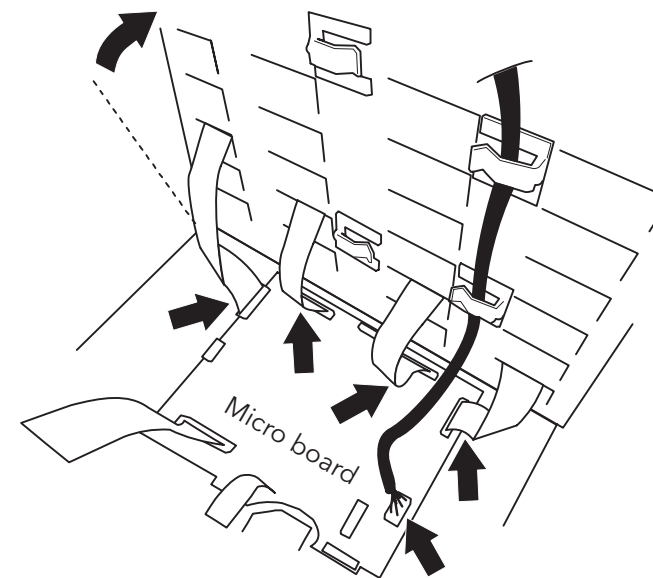
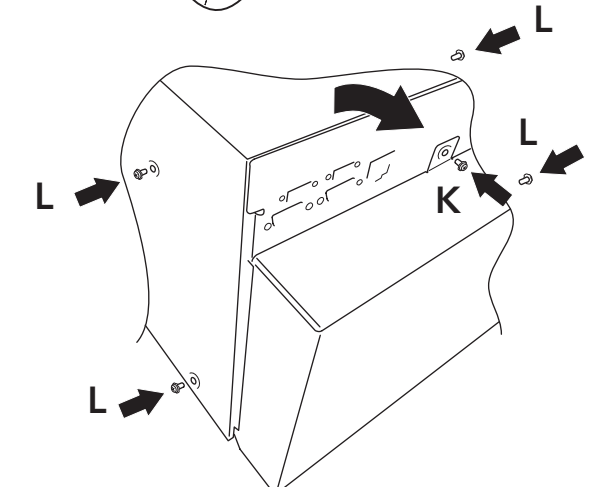

9 Unclip the power loom, battery loom and (if fitted) the serial comms and USB looms. Remove the circuit board retainer by removing the plastic rivets 'M', undoing the two securing screws 'N', and carefully lifting it away from the card cage, ensuring that no damage is done to the various flexies.

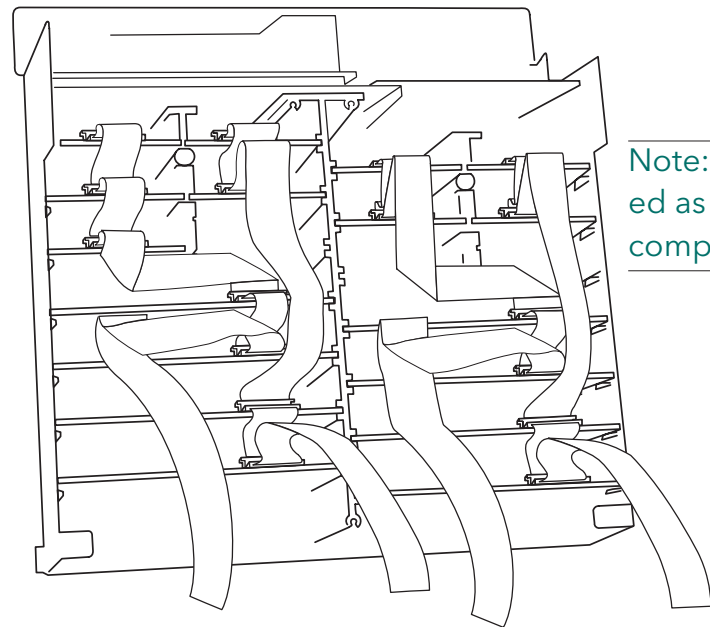

Note: The flexi-cables must be routed and folded as shown, otherwise, the unit will not be CE compliant when re-assembled.

10

If necessary, fit extra connectors* and associated EMC springs* at the rear of the recorder. Select a label appropriate to the type of new board being added, and apply it to the connector (see page 4).

Continue at instruction 11a, if one or more input boards are to be fitted, or at instruction 13, if only option boards are being fitted.

*Notes:

1. If required, insert polarising plugs in the appropriate place for the type of board being fitted (see the table on page 4).
2. Input boards require an EMC spring at both ends of the connector. Option boards require one EMC spring each, fitted at the relevant end of the connector.

FITTING A FURTHER INPUT BOARD

11a

Before fitting a new input board, a link must be set to define the board number. Although there can be up to eight input boards fitted, there are only two per I/O port on the micro-board. It is thus necessary only to define the board as board 1 or board 2, as shown on page 3 of this document. The figure below shows the slot numbers for all possible input and option boards.

15

Carefully re-assemble the recorder, ensuring that the flexi-cables are correctly routed through the appropriate slots in the board retainer, and that the retainer is correctly located, before attempting to secure it.

Ensure that all connections to the micro board are secure and that the flexi-cables are securely retained. The figure below shows the relevant connector locations on the micro board.

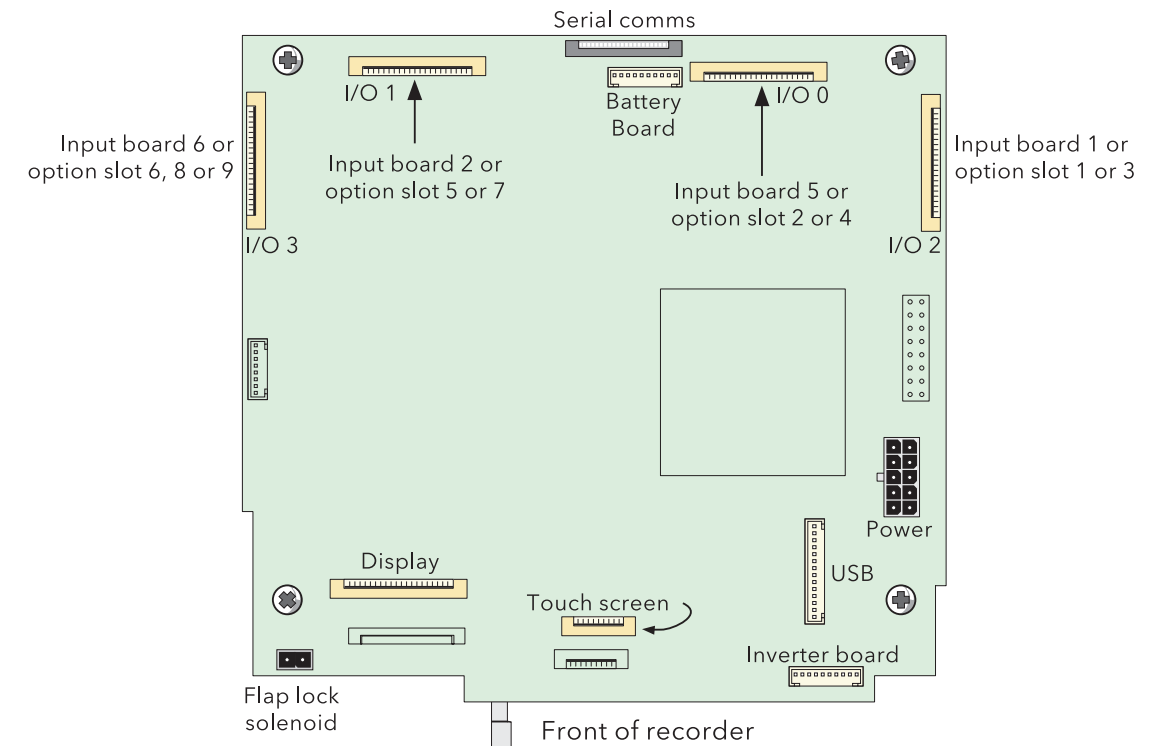

Wire the new connectors according to the information contained in the following pages

16

Apply power to the recorder. Once initialization is complete it is likely that a request to autoconfigure dialogue page will appear. This is only a reminder - pressing OK does not carry out the Autoconfigure.

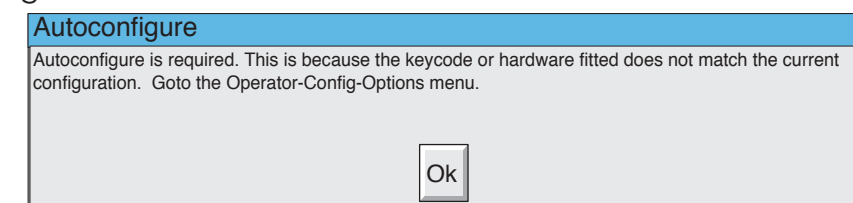

Log in.

If necessary (i.e. if a new Serial Communications or other software option has been fitted), enter the option key code as described under 'Option Enabling' in the reference section of the Installation and Operation Manual.

From the Root key menu select Operator, then 'Config', then 'Options'. Press the Autoconfigure key to complete installation (page 16).

14 (cont.)**FITTING AN OPTION BOARD (CONT.)**

To fit option board 5, fit the board, and connect it to input board 4 (if fitted), or to input board 2 (if fitted), using a 180 mm long flexi-cable. If neither input board is fitted, fit a 270 mm length of flexi-cable into the horizontal connector. On re-assembly, this flexi-cable is connected to I/O 1 on the micro board.

If fitting a board into option slot 6, fit the board, and connect it to input board 8 (if fitted), or to input board 6 (if fitted), using a 180 mm long flexi-cable. If neither input board is fitted, fit a 270 mm length of flexi-cable into the horizontal connector. On re-assembly, this flexi-cable is connected to I/O 3 on the micro board.

If fitting a board into option slot 7, remove the flexi-cable from the horizontal connector of option board 5. Insert a 50 mm long flexi-cable into the vertical connector of the new board. Slide the option board into its slot, and connect it to option board 5 using the 50 mm

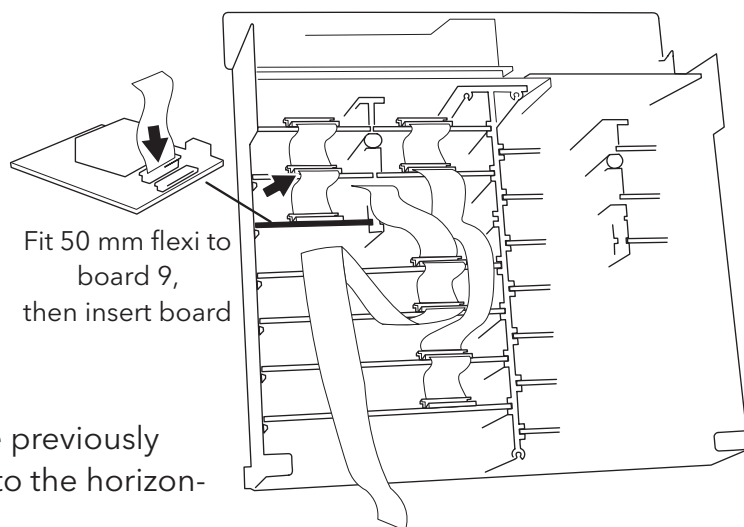

Fit 50 mm flexi to board 9, then insert board

flexi-cable just fitted. Take the flexi-cable previously removed from option board 5, and fit it to the horizontal connector of option board 7.

To fit option board 8, remove the flexi-cable from the horizontal connector of option board 6 and insert it into the horizontal connector of option board 8. Insert a 50 mm long flexi-cable into the vertical connector of option board 8. Slide the option board into its slot, and use the 50 mm flexi-cable to connect to the horizontal connector on option board 6.

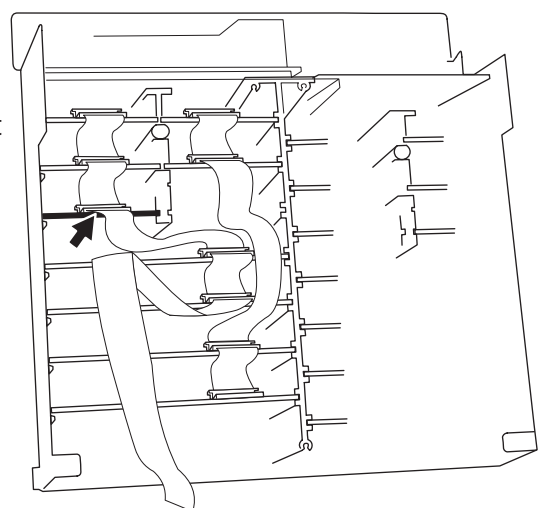

Fit flexi to board 9

To fit option board 9 (as shown), remove the flexi-cable from the horizontal connector of option board 8. Insert a 50 mm long flexi-cable into the vertical connector of option board 9. Slide the option board into its slot, and use the 50 mm flexi-cable to connect to the horizontal connector on option board 8.

Take the flexi-cable previously removed from option board 8, and insert it into the horizontal connector of option board 9.

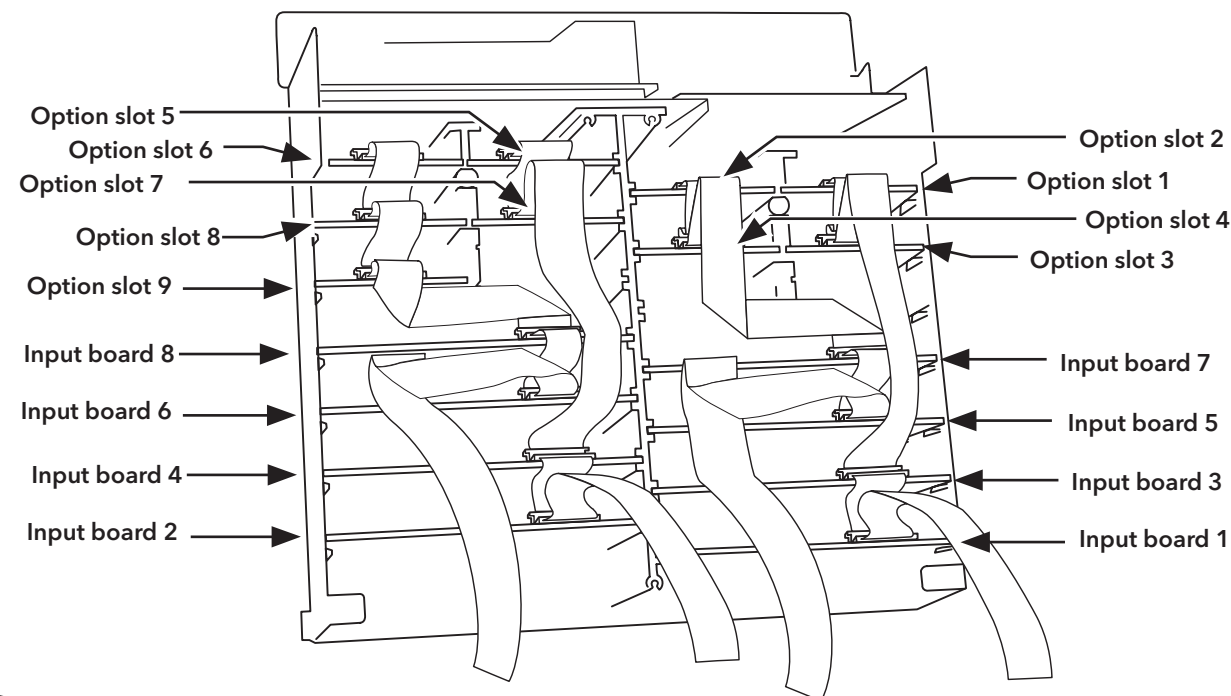
**11b****Notes:**

- 1 Flexi-cable is not 'double sided'. At the ends, one face is 'live'; the other is insulated. The insulated side of the flexi should always face the latching bar of the connector.
2. It may be necessary to disconnect some flexi cables, that are not directly associated with the new board being fitted, in order to gain access to the board slot more easily.

To fit input board 2. If option boards 5 and/or 7 are fitted, remove the flexi-cable which previously connected the option boards with I/O 1 on the micro board. Fit 180 mm long flexi-cables to both the vertical and horizontal connector of the new input board. Slide the board into its slot, and connect it to the horizontal connector on option board 5 or 7, whichever is physically the lower.

If neither option board is fitted, fit a 180 mm long flexi-cable to the input board horizontal connector and slide the board into its slot.

To fit input board 3. Disconnect the flexi cable (if any) currently fitted to the vertical connector of input board 1. Fit a 50 mm long flexi-cable to this connector. Take the new input board, and slide it into its slot. Connect its horizontal connector to the vertical connector of input board 1, using the 50 mm flexi-cable just fitted. Fit the flexi-cable (if any) previously fitted to the vertical connector of input board 1, and fit it to the vertical connector of input board 3.

To fit input board 4. Disconnect the flexi cable (if any) currently fitted to the vertical connector of input board 2. Fit a 50 mm long flexi-cable to this connector. Take the new input board, and slide it into its slot. Connect its horizontal connector to the vertical connector of input board 2, using the 50 mm flexi-cable just fitted. Fit the flexi-cable (if any) previously fitted to the vertical connector of input board 2, and fit it to the vertical connector of input board 4.

(Continued)

11b (cont.)**FITTING A FURTHER INPUT BOARD (CONT.)**

To fit input board 5. Fit a 270 mm long flexi-cable to the input board's horizontal connector and slide it into its slot.

If option boards 4 and/or 2 are fitted, remove the flexi-cable which previously connected the option board(s) with I/O 0 on the micro board. Use a 180 mm flexi-cable to connect the horizontal connector on option board 2 or 4 (whichever is physically the lower), to the vertical connector of the new input board.

Connect the other end of the input board flexi to I/O 0 on the micro board.

To fit input board 6. Fit a 270 mm long flexi-cable to the its horizontal connector and slide it into its slot.

If option boards 6 and/or 8 and/or 9 are fitted, remove the flexi-cable which previously connected the option board(s) with I/O 3 on the micro board. Use a 180 mm flexi-cable to connect the horizontal connector on option board 6, 8 or 9 (whichever is physically the lowest), to the vertical connector of the new input board.

Connect the other end of the input board flexi to I/O 3 on the micro board.

To fit input board 7. Disconnect the flexi cable (if any) currently fitted to the vertical connector of input board 5. Fit a 50 mm long flexi-cable to this connector. Take the new input board, and slide it into its slot. Connect its horizontal connector to the vertical connector of input board 5, using the 50 mm flexi-cable just fitted. Take the flexi-cable (if any) previously fitted to the vertical connector of input board 5, and fit it to the vertical connector of input board 7.

To fit input board 8. Disconnect the flexi cable (if any) currently fitted to the vertical connector of input board 6. Fit a 50 mm long flexi-cable to this connector. Take the new input board, and slide it into its slot. Connect its horizontal connector to the vertical connector of input board 6, using the 50 mm flexi-cable just fitted. Take the flexi-cable (if any) previously fitted to the vertical connector of input board 6, and fit it to the vertical connector of input board 8. (If option slots 6, 8 or 9 are occupied, a flexi 180 mm long should be used.)

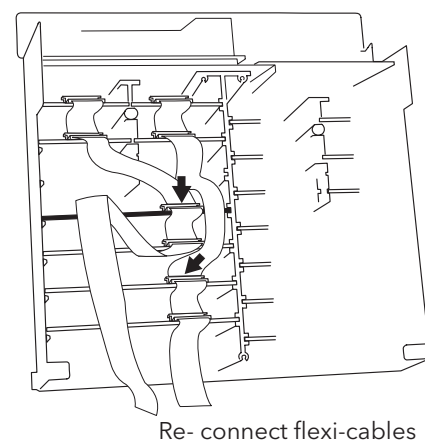
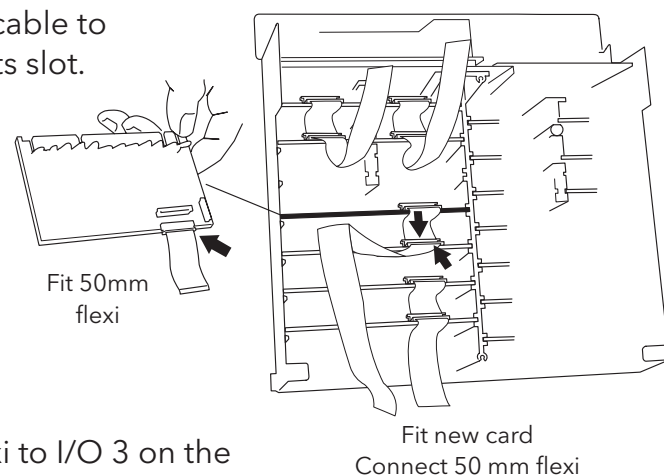
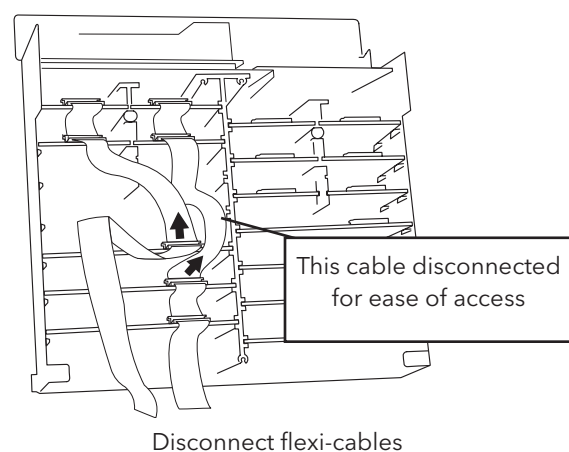
**12**

If option boards are also to be fitted, continue at instruction 13. If not, continue at instruction 15.

13**FITTING AN OPTION BOARD**

Continuing from instruction 10, set any relevant switches or links, on the new board(s), as described on page 3. See also the Board location rules on page 1. If necessary, fit one or more circuit board support extensions. (The figure shows not only how to fit an extension, but also how to fit a top support extrusion, which is necessary only when fitting a board in option slot 1/2 or 5/6 for the first time.)

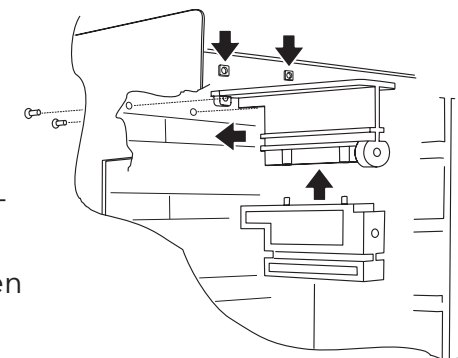
**14****Notes:**

- 1 Flexi-cable is not 'double sided'. At the ends, one face is 'live'; the other is insulated. The insulated side of the flexi should always face the latching bar of the connector.
2. It may be necessary to disconnect some flexi cables, that are not directly associated with the new board being fitted, in order to gain access to the board slot more easily.
3. See page 9 for a slot location drawing.

The following assumes that a new board is being fitted to a previously unused slot. If this is not the case (e.g. a faulty board is being replaced), then the same length flexi-cables should be used for the replacement board as were used on the board being replaced. It is also assumed that only a single board is being fitted. If more than one board is being fitted, the procedure is similar, but it must be ensured that the flexi-cable chains are arranged as shown electrically on page 2, and physically on page 8 or 9, according to version.

If fitting a board into option slot 1, fit the board, and use a 180 mm long flexi-cable to connect it to input board 3 (if fitted), or to input board 1 (if fitted). If neither input board is fitted, use a 270 mm long flexi-cable to connect the option board to I/O2 on the micro-board.

If fitting a board into option slot 2, and neither input board 5 nor 7 is fitted, insert a 270 mm long flexi-cable into the horizontal connector and slide the board into its slot. Connect the other end of this flexi to I/O 0 on the micro board. If either input board is fitted, connect the horizontal connector of option board 2 to the vertical connector of input board 7 (if fitted) or board 5, using a 180 mm long flexi-cable.

If fitting a board into option slot 3, remove the flexi-cable fitted to the horizontal connector of Option board 1. Insert a 50 mm long flexi-cable into the vertical connector of the new board. Slide the option board into its slot, and connect it to option board 1 using the 50 mm flexi-cable just fitted. Use a 180 mm long flexi-cable to connect the option board's horizontal connector to the vertical connector of input board 3, if fitted, or input board 1 (if fitted). If no input board is fitted, use a 270 mm flexi-cable to connect the option board to I/O 2 on the microboard

To fit option board 4, remove the flexi-cable from option board 2, and insert it into the horizontal connector of the new option board. Insert a 50 mm long flexi-cable into the vertical connector. Slide the option board into its slot, and use the 50 mm flexi-cable to connect to the horizontal connector on option board 2.

(Continued)