

ULTRA SLIMPAK® II MODEL WV128-2000

Thermocouple Input Limit Alarm

Installation and Calibration Instructions

NOTE: The unit has been shipped with the Power Clips attached. Please remove the clips before installing the module on the DIN rail. If the Power Clips are chosen as the means to route power, they can be installed once the modules are in place on the DIN rail.

DIN Rail Mounting

The WV128 mounts on a 35mm TS35 DIN rail, by simply hooking one side of the mounting foot over the rail and pressing the module towards the rail until it locks into place. To remove the unit from the rail, place the tip of a flat-bladed screwdriver under the release clip on either the top or the bottom of the module and pry up until the module releases from the rail. See Figure 1.

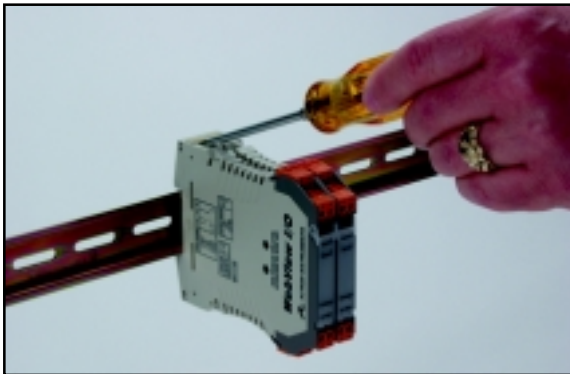

Figure 1

until the two tabs lock firmly in place. This may require pressing on the front side of the upper and lower terminal blocks for a positive fit. The board slides in where the switch and the switch position chart on the case can be viewed together.

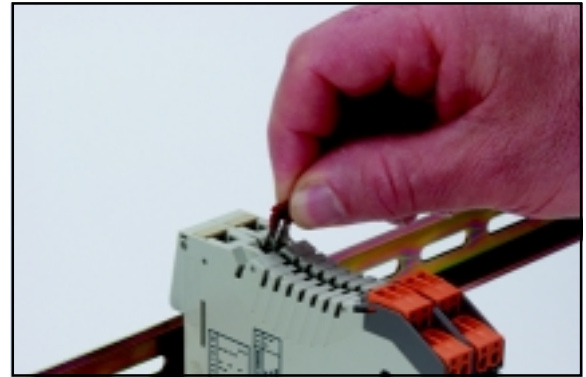
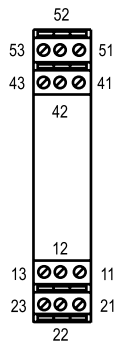

Figure 2

Wiring Connections



Pin	Description
11	N.O. Relay B
12	Com. Relay B
13	N.C. Relay B
21	DC Power (+)
22	DC Power (-)
23	No Connection
41	T/C Input (+)
42	T/C Input (-)
43	No Connection
51	N.O. Relay A
52	Com. Relay A
53	N.C. Relay A

Power Connections

The power jumper clips (see Figure 2) are used to distribute power to a maximum of 16 modules. In applications using more than 16 modules, power wiring must be connected to the first and last module, and distributed to the remaining modules using the power clips. This technique allows for "hot swapping" of a module without interrupting power to the remaining units.

Opening the Case

The case can be opened by simultaneously pressing in on the two ribbed tabs located at the top and bottom of the front cap of the case and sliding out the circuit board. This provides easy access to the DIP switch for range selection. To close the case, slide the board back in

Description

There are two standard versions of the WV128, the WV128-2000 and the WV128-2001. The WV128-2000 uses standard (non-latching) relays - when a power loss occurs, the form "C" relay transitions to its "relaxed" state. The WV128-2001 uses latching relays - when a power loss occurs, the relay remains in its current position. A manual reset is required to change the state of the relay.

Input Range Configuration

Unless otherwise specified, the factory presets the Model WV128 as follows:

Input: Type J
 Output: Dual, SPDT
 Trip: A: HI, B: LO
 Failsafe: No
 Deadband: A, B: minimum

1. For other ranges, refer to the Switch Settings Table. Reconfigure switch S1 for the desired input type and range.
2. Set position 1 of S1 to ON if a WVC16 will be utilized and remote calibration capability is desired.
3. Set position 2 and 3 of S1 to ON for a Hi trip setpoint or to OFF for a Low trip setpoint. (A can be set for a high trip and B can be set for a low trip.)
4. Set position 4 of S1 to ON for failsafe operation (e.g. alarm trips on power failure) or OFF for non-failsafe operation (only on the -2000 version).

Switch Settings

Function	S1							
	1	2	3	4	5	6	7	8
Input								
+80mV/-20mV	-	-	-	-	■	■	■	
B t/c	-	-	-	-	■	■		
E t/c	-	-	-	-	■		■	
J t/c	-	-	-	-	■			
K t/c	-	-	-	-		■	■	
R t/c	-	-	-	-		■		
S t/c	-	-	-	-			■	
T t/c	-	-	-	-				
Remote Cal Enable	■	-	-	-	-	-	-	
A Hi/Low (Hi)	-	■						
B Hi/Low (Hi)	-		■					
Failsafe	-	-	-	■				

Key: ■ = 1 = ON or Closed; - = n/a

Diagnostic LEDs

Other than when executing the pushbutton calibration routine, the LED's operate under the following conditions:

RUN (Green): On when unit is powered.
Flashes at 2Hz when the input is under range.
Flashes at 8Hz when the input is over range.

SETPOINT A (Red): On when Setpoint A is tripped.
On when setting Setpoint A.
Flashes while calibrating the input level.

SETPOINT B (Red): On when Setpoint B is tripped.
On when setting Setpoint B.
On while calibrating the input level.

An Over/Under Range condition exists at or near the operational range limits.

Operation

The WV128 limit alarm setpoints can be configured for HI or LO, failsafe or non-failsafe operation (failsafe is only available on the -2000). Both setpoints have individually adjustable deadbands. In a tripped condition, the setpoint is exceeded and the appropriate red LED will illuminate. The trip will reset only when the process falls below the HI release point or rises above the LO release point (see Figure 3). Minimum deadband values are listed in the specifications.

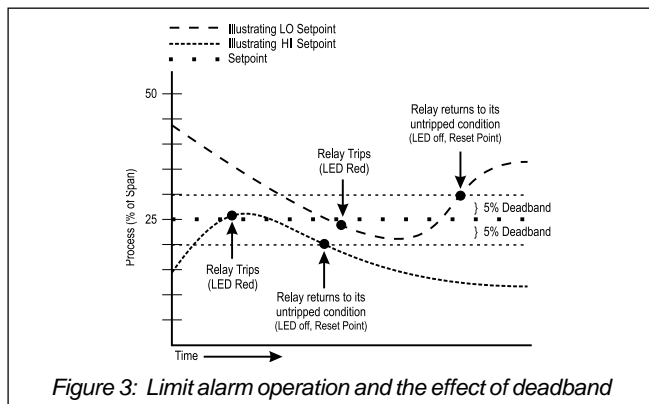

Figure 3: Limit alarm operation and the effect of deadband

For proper deadband operation, the HI setpoint must always be set above the LO setpoint. In failsafe operation (-2000 only), the relay is energized when the process is below the HI setpoint or above the LO setpoint (opposite for non-failsafe). In the failsafe mode, a power failure results in an alarm state output.

Calibration

For best results, calibration should be performed in the operating environment, mounted on a DIN rail, allowing at least one hour for thermal equilibrium of the system. An Over/Under Range condition exists at or near the operational range limits. If calibrating the -20/80mV input range, it should be performed first. All T/C input ranges are based upon the mV range calibration. Refer to the calibration flow chart, Figure 6. This procedure will set the input range first and then proceed to the setpoints.

NOTE:

Changing the +80/-20 mV input calibration is not recommended. If you must calibrate the +80/-20 mV input range, the input source should be a Fluke 5500A calibrator (or a source of equal precision). To bypass the input calibration and go directly to the setpoints, simply set the Input DIP switch for the T/C desired and skip to Step 6. If performing the Input calibration, set the Input DIP switch to +80/-20mV and proceed to Step 1.

1. Connect the input to the calibrated source called out above. Apply power and allow the system to reach thermal equilibrium.

2. Adjust the input signal to the desired maximum and observe that the Green LED is on or flashing. Push and hold the CAL button for 4 seconds. The Green LED will be flashing and the upper Red LED will be on. Press the CAL button twice. This brings you to the beginning of the input cal section. The Green and both Red LEDs should be flashing. Press and hold the CAL button for 10 seconds or until the Upper Red LED is flashing. Press and hold the CAL button for 4 seconds. The upper Red LED will be flashing and the Green and lower Red LEDs will be on. From this point on, you can exit the calibration procedure without saving new data by holding the CAL button for at least 4 seconds.

3. Apply an 80.000mV input signal and push the CAL button. The upper Red LED will still be flashing and the lower Red LED will be on.

4. Apply a -20.000mV input signal level and push the CAL button. All three LEDs should be on.

5. Push the CAL button again. The calibration data is now saved. The Green LED should be on if the input is within the calibrated range.

6. The Setpoints can now be set. This procedure assumes Setpoint A is a HI trip setpoint and Setpoint B is a LOW trip setpoint. Unlike previous models, there is no deadband pot to adjust - simply set the trip point and the release point for each relay.

Adjust the input signal to the desired trip level for Setpoint A and observe that the Green LED is on. Push and hold the CAL button for 4 seconds. The Green LED will be flashing and the upper Red LED will be on. Press and hold the CAL button for 4 seconds. Both the upper Red LED and the Green LED will be flashing.

7. With the trip signal level applied to the input, press the CAL button. The Green LED will now be flashing.

8. For the minimum deadband, press the CAL button, otherwise, reduce the input level to the desired release point and press the CAL

button. All three LEDs will be on. To save the calibration, press the CAL button. The Green LED should be on.

9. Adjust the input signal down to the desired trip level for Setpoint B and observe that the Green LED is on. Push and hold the CAL button for 4 seconds. The Green LED will be flashing and the upper Red LED will be on. Press the CAL button once. The lower Red LED will be on and the Green LED will be flashing.

10. Press and hold the CAL button for 4 seconds. Both the Lower Red LED and the Green LED will be flashing. With the trip voltage applied to the input, press the CAL button. The Green LED will now be flashing.

11. For the minimum deadband, press the CAL button, otherwise, increase the input level to the desired release point and press the CAL button. All three LEDs will be on. To save the calibration, press the CAL button. The Green LED should be on.

Relay Protection and EMI Suppression

When switching inductive loads, maximum relay life and transient EMI suppression is achieved using external protection (see Figures 4 and 5). Place all protection devices directly across the load and minimize all lead lengths. For AC inductive loads, place a properly rated MOV across the load in parallel with a series RC snubber. Use a 0.01 to 0.1 uf pulse film capacitor (foil polypropylene recommended) of sufficient voltage, and a 47 Ohm, 1/2Watt carbon resistor. For DC inductive loads, place a diode across the load (PRV > DC supply, 1N4006 recommended) with (+) to cathode and (-) to anode (the RC snubber is an optional enhancement).

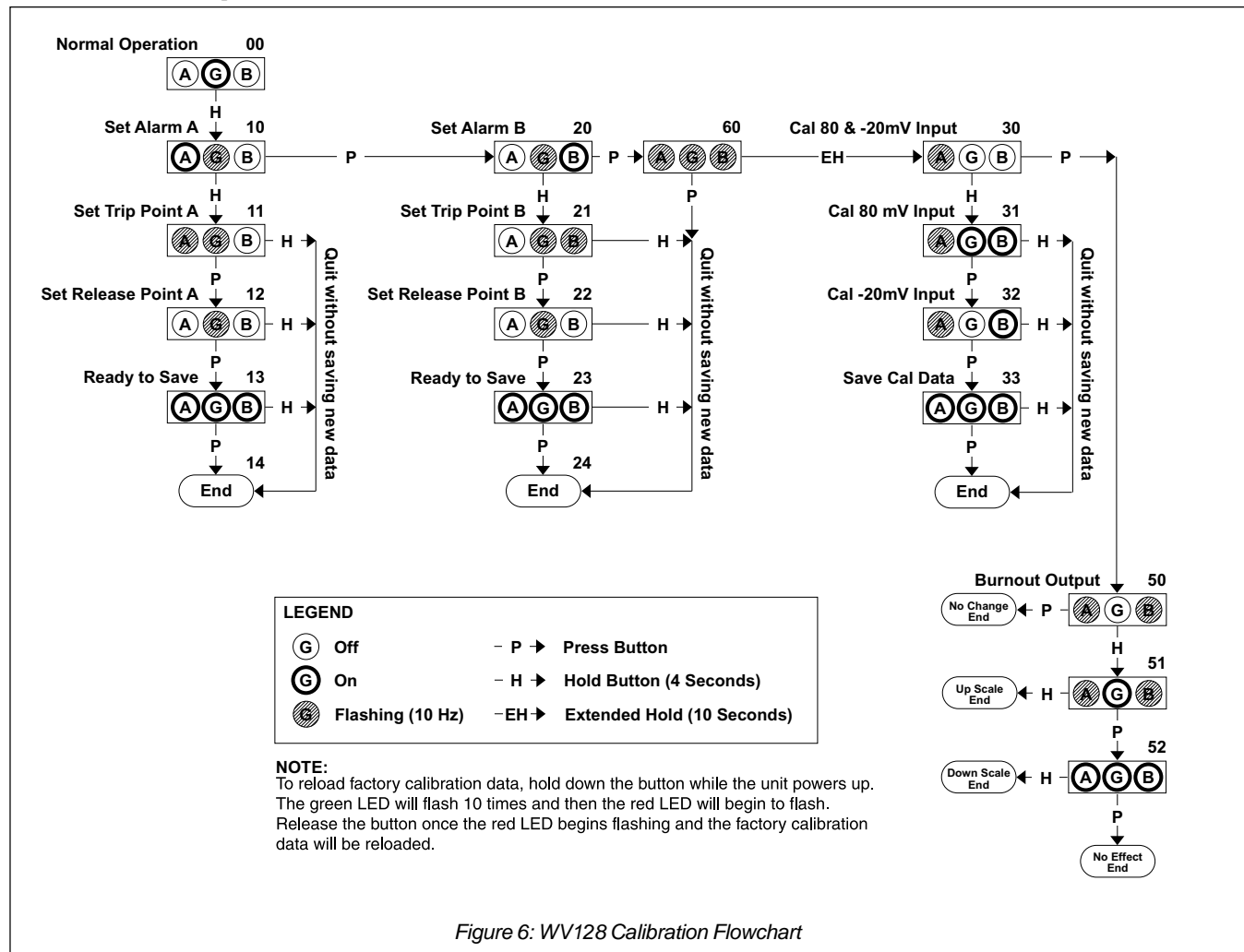
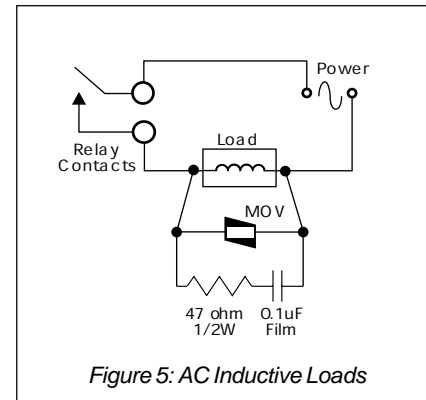
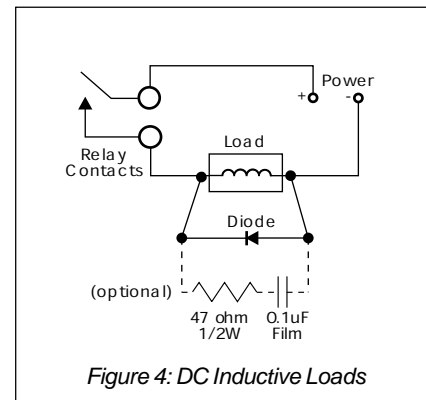

Specifications

Inputs

Thermocouples Supported: B, E, J, K, R, S, T

Ranges: T/C Type	°C	°F
B	+75 to 1820	+167 to 3308
E	-265 to 1000	-445 to 1832
J	-210 to 760	-346 to 1400
K	-265 to 1372	-445 to 2502
R	-25 to 1760	-13 to 3200
S	-25 to 1760	-13 to 3200
T	-265 to 390	-445 to 734

Overvoltage: ±10V differential

Common Mode: 1800VDC (Input to Ground)

Limit Differentials (deadbands) 0.2% to 100% of span

Set by Pushbutton Adjustment.

Response Time

Dynamic Deadband: Relay status will change when proper setpoint/process condition exists for 100mSec.

Normal Mode: <250mSec (analog filtering)

Setpoint Effectivity: Setpoints are adjustable (by pushbutton) over 100% of the selected input span

Repeatability: ±0.05% of FS, ±1°C (constant temperature)

Relay Contacts

2 SPDT (2 form C) Relays; 1 relay per setpoint

Current rating (general use)

120VAC: 5A; 240VAC: 2A; 28VDC: 5A

Material: Gold flash over silver alloy

Electrical Life: 10⁵ operations

Reset Switch

To cycle the relay without cycling power to the unit. (WV128-2001 only)

Local Range Selection

By DIP switch

Stability

±100ppm of FS/°C

Common Mode Rejection

120dB @ DC, >90dB @ 60Hz, or better

Isolation

≥ 1800VDC or peak AC between contacts, input & power

ESD Susceptibility

Capable of meeting IEC 801-2 level 3 (8kV)

Power

9 to 30VDC,

1.2W typical (3.25W max w/ both relays energized)

Host Module Interface

IR link, same specifications as Phase 1 modules

Wire Terminations

Screw terminations for 12-22 AWG

Size

DIN rail case – 17.5mm (0.69") wide. Refer to Dimensions drawing.

Environmental

Operating Temperature: 0°C to +60°C (32 to 140°F)

Storage Temperature: -25°C to +85°C (-13 to 185°F)

Operating Humidity: 15 to 95% RH, non-condensing @45°C

Soak: 90% RH, non-condensing for 24hrs @60°C

Agency Approvals (EMC & Safety)

CE, EN61326, EN61010-1

UL and CSA Combined mark

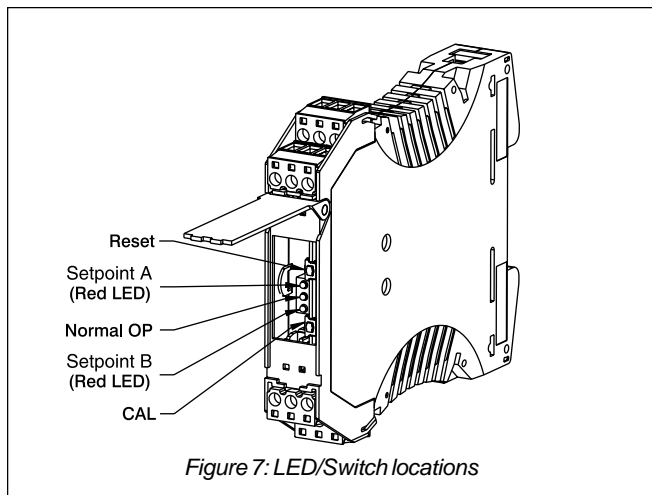
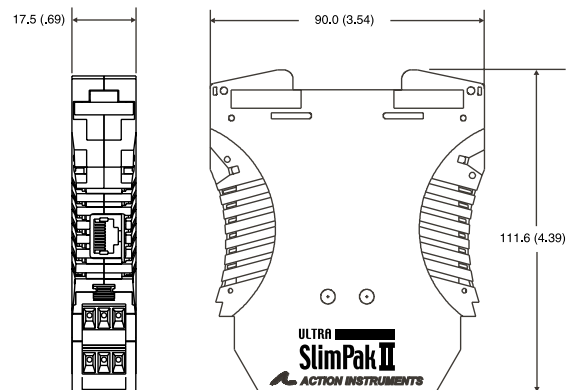

Figure 7: LED/Switch locations

Dimensions

Dimensions are in mm (inches)



Eurotherm Controls

741-F Miller Drive

Leesburg, VA 20175-8993

703-443-0000

info@eurotherm.com

Factory Assistance

For additional information on calibration, operation and installation contact our Technical Services Group:

703-669-1318

actionsupport@eurotherm.com

HA136738WV128 Rev - Copyright © Eurotherm, Inc 2004